

DIAMOND C-60+ Series OEM Lasers

Preinstallation Manual

Preinstallation Manual
DIAMOND C-60+ Series
OEM Lasers



COHERENT.

1280 Blue Hills Avenue
Bloomfield, CT 06002

This document is copyrighted with All Rights Reserved. Under copyright laws, this document must not be copied in full or in part, or reproduced by any other media, without the express written permission of Coherent, Inc. (Coherent). Permitted copies must have the same proprietary and copyright notices as were attached to the original. This exception does not permit copies—whether or not sold—to be made for others; however, all the material purchased can be sold, given, or loaned to another person. Under the law, “copying” includes translation into another language.

Coherent and the Coherent Logo are registered trademarks of Coherent, Inc. All other trademarks or registered trademarks are the property of their respective owners.

Patents referenced in this manual are active when the manual is printed (see last page for the revision date). It is advised to check www.coherent.com/company/patents to see if the patents are still active.

Every effort was made to make sure that the data shown in this document is accurate. The information, figures, tables, specifications, part numbers, and schematics contained in this manual are subject to change without notice. Coherent makes no warranty or representation, either expressed or implied, related to this document. In no event will Coherent be liable for any direct, indirect, special, incidental, or consequential damages caused by any defects in its documentation.

Technical Support

In the U.S.:

Should there be any difficulties with the laser or a need for any technical information, go to the Coherent website www.coherent.com. If further assistance is still needed, contact Coherent Technical Support by email customer.support@coherent.com or telephone, +1-734-456-3100. Be prepared to supply the model and laser head serial number of the laser system. Also include a description of the problem and any attempted corrective steps to the Product Support Engineer responding to the request.

Telephone coverage is available Monday through Friday (except U.S. holidays and company shutdowns). Inquiries received outside of normal office hours will be captured by the Coherent automatic answering system and will be quickly returned the next business day.

Outside the U.S.:

If located outside the U.S., visit www.coherent.com for technical assistance or contact the local Service Representative. Service Representative telephone numbers and addresses can be found on the Coherent website.

Coherent provides telephone and web-based technical assistance as a service to its customers and assumes no liability for any injury or damage that can occur at the same time with such services. Under no conditions do these support services affect the terms of any warranty agreement between Coherent and the Buyer. Operation of any Coherent laser with any of its interlocks defeated is always at the operator's own risk.

TABLE OF CONTENTS

1 Introduction	1
1.1 Signal Words and Symbols in This Manual	1
1.1.1 Signal Words	1
1.1.2 Symbols	2
1.2 Preface	3
1.3 Export Control Laws Compliance	4
1.4 Notice Concerning Regulatory Status of DIAMOND Series Lasers	4
1.5 Notice Concerning Warranty	4
1.6 The Preinstallation Manual	5
1.6.1 Intended Audience	5
1.6.2 Numbering of Sections, Pages, and Instructions	5
1.6.3 Cited Standards	6
1.7 Units of Measurements	6
1.8 Feedback Regarding Documentation	7
1.8.1 Feedback Address	7
2 Laser Safety	9
2.1 Hazards	9
2.1.1 Optical Safety	10
2.1.1.1 Recommended Precautions and Guidelines	10
2.1.1.2 Laser Safety Eyewear	11
2.1.1.3 Viewing Distance	12
2.1.2 Electrical Safety	13
2.1.2.1 Recommended Precautions and Guidelines	13
2.2 Safety Features and Compliance with Government Requirements	14
2.2.1 Laser Classification	14
2.2.2 Protective Housing	14
2.2.3 Protective Covers (Safety Interlocks)	15
2.3 Compliance to Standards Relevant to CE Mark	15
2.4 Environmental Compliance	15
2.4.1 Electromagnetic Compatibility	16
2.4.2 RoHS Compliance	16
2.4.3 China RoHS Compliance	16
2.4.4 EU REACH	17
2.4.5 Waste Electrical and Electronic Equipment (WEEE)	18
2.5 Labeling	18
2.6 Sources of Additional Information	24

2.6.1 Laser Safety Standard	24
2.6.2 Publications and Guidelines	24
3 Description and Specifications	25
3.1 Introduction.....	25
3.2 Purpose of This Manual	25
3.3 Configuration	25
3.4 Hardware Overview	27
3.4.1 DC Input Power	27
3.5 Cooling Requirements	28
3.5.1 Comparison of Air Cooling & Liquid Cooling (Reference)	28
3.5.2 Liquid Cooling Option of the C-60+ Series	29
3.6 Laser Head.....	29
3.7 RF Power Module	30
3.8 Configuration and Facility Requirements	30
4 Utility Requirements and System Installation	33
4.1 Introduction.....	33
4.2 Unpacking and Inspection	33
4.2.1 Verifying Delivery	33
4.2.2 Protective Shipping Tape.....	34
4.2.2.1 Tape Removal.....	34
4.3 Safety Issues in Laser Installation	35
4.4 Mechanical Mounting	36
4.4.1 Mounting Considerations for the C-60+ Series	40
4.5 Ambient Air Cleanliness	40
4.6 Ingress Protection (IP) Certification	41
4.7 Air Cooling	42
4.7.1 Air Flow	42
4.7.2 Air Flow Inspection	42
4.7.3 Signal Interface.....	42
4.8 Liquid Cooling.....	43
4.8.1 Cooling System Layout.....	43
4.8.2 Coolant Composition	44
4.8.2.1 Freeze/Burst Protection	45
4.8.3 Alternative Coolant Composition.....	46
4.8.4 Freeze/Burst Protection	48
4.8.5 Re-Circulation and Coolant Flow Interlock Switch.....	48
4.8.6 Signal Interface.....	48
4.8.7 Thermal Shutdown Circuit.....	49
4.8.8 DC Power Relay.....	49

4.8.9	Condensation of Water Vapor.....	49
4.8.10	Coolant Fittings on Laser System.....	50
4.8.11	Cooling Capacity.....	51
4.8.12	Coolant Filtering.....	51
4.8.13	Coolant Flow Rate and Pressure.....	51
4.8.14	Pressure Drop.....	52
4.9	Electrical Power Connection.....	52
4.9.1	DC Power Supply Requirements.....	53
4.9.1.1	DC Power Supply Cabling Requirements.....	53
4.10	Control Signal Connection.....	54
4.11	Beam Propagation.....	56

LIST OF ILLUSTRATIONS

2-1.	Nominal Ocular Hazard Distance (NOHD).....	12
2-2.	Environment-Friendly Use Period Symbol.....	17
2-3.	Manufacture Date.....	17
2-4.	Waste Electrical and Electronic Equipment Label.....	18
2-5.	Location of Safety Labels for Air-Cooled Lasers.....	19
2-6.	Location of Safety Labels for Liquid-Cooled Lasers.....	21
2-7.	Labels.....	22
3-1.	C-60+ Series Air-Cooled and Liquid-Cooled Lasers.....	26
3-2.	Cooling System Diagram.....	29
4-1.	Protective Shipping Tape.....	34
4-2.	C-60+ Series Air-Cooled and Liquid-Cooled Laser Head Dimensions.....	36
4-3.	Recommended Liquid Cooling System Functional Block Diagram.....	43
4-4.	Water Circuits - Untreated and Treated.....	45
4-5.	C-60+ Series Liquid Cooling Connections.....	50
4-6.	Beam Diameter vs. Distance from Laser Head.....	56

LIST OF TABLES

3-1.	Comparison: The Benefits of Air Cooling vs. Liquid Cooling Methods	28
3-2.	C-60+ Series Configuration and Facility Requirements	30
4-1.	Recommended Coolant for C-60+ Series Lasers	44
4-2.	Propylene Glycol-Based Heat Transfer Fluids for C-60+ Series Lasers.....	46
4-3.	Ethylene Glycol-Based Heat Transfer Fluids for C-60+ Series Lasers	47
4-4.	Signal Interface Description and Connector Pinout.....	54

1 INTRODUCTION

1.1 Signal Words and Symbols in This Manual

This documentation may contain sections in which particular hazards are defined or special attention is drawn to particular conditions. These sections are indicated with signal words in accordance with ANSI Z-535.6 and safety symbols (pictorial hazard alerts) in accordance with ANSI Z-535.3 and ISO 7010.

1.1.1 Signal Words

Four signal words are used in this documentation: **DANGER**, **WARNING**, **CAUTION**, and **NOTICE**.

The signal words **DANGER**, **WARNING**, and **CAUTION** designate the degree or level of hazard when there is the risk of injury:

DANGER!

Indicates a hazardous situation that, if not avoided, will result in death or serious injury. This signal word is to be limited to the most extreme situations.

WARNING!

Indicates a hazardous situation that, if not avoided, could result in death or serious injury.

CAUTION!

Indicates a hazardous situation that, if not avoided, could result in minor or moderate injury.

The signal word "**NOTICE**" is used when there is the risk of property damage:

NOTICE

Indicates information considered important, but not hazard- related.

Messages relating to hazards that could result in both personal injury and property damage are considered safety messages and not property damage messages.

1.1.2

Symbols

The signal words **DANGER**, **WARNING**, and **CAUTION** are always emphasized with a safety symbol that indicates a special hazard, regardless of the hazard level:



This symbol is intended to alert the operator to the presence of additional information.



This symbol is intended to alert the operator to the presence of important operating and maintenance instructions.



This symbol is intended to alert the operator to the danger of exposure to hazardous visible and invisible laser radiation.



This symbol is intended to alert the operator to the presence of dangerous voltages within the product enclosure that may be of sufficient magnitude to constitute a risk of electric shock.



This symbol is intended to alert the operator to the danger of Electro-Static Discharge (ESD) susceptibility.



This symbol is intended to alert the operator to the danger of crushing injury.



This symbol is intended to alert the operator to the danger of a lifting hazard.

1.2

Preface

This is the preinstallation manual for the DIAMOND C-60+ Series OEM/ Industrial laser manufactured by Coherent. These lasers are OEM systems; they are designed as components which are to be inserted by the original equipment manufacturer (OEM) prior to delivery to the end user. Coherent requires that the user read "Laser Safety" (p. 9), before operating the laser.



NOTICE!

Read this manual carefully before operating the laser for the first time. Failure to follow the instructions and safety precautions in this manual can result in serious injury or death. Special attention must be given to the material in "Laser Safety" (p. 9), that describes the safety features built into the laser. Keep this manual with the product and in a safe location for future reference.



DANGER!

Use of controls or adjustments or performance of procedures other than those specified herein may result in hazardous radiation exposure.

1.3 Export Control Laws Compliance

It is the policy of Coherent to comply strictly with U.S. export control laws.

Export and re-export of lasers manufactured by Coherent are subject to U.S. Export Administration Regulations, which are administered by the Commerce Department. In addition, shipments of certain components are regulated by the State Department under the International Traffic in Arms Regulations.

The applicable restrictions vary depending on the specific product involved and its destination. In some cases, U.S. law requires that U.S. Government approval be obtained prior to resale, export or re-export of certain articles. When there is uncertainty about the obligations imposed by U.S. law, clarification must be obtained from Coherent or an appropriate U.S. Government agency.

Products manufactured in the European Union, Singapore, Malaysia, Thailand: These commodities, technology, or software are subject to local export regulations and local laws. Diversion contrary to local law is prohibited. The use, sale, re-export, or re-transfer directly or indirectly in any prohibited activities are strictly prohibited.

1.4 Notice Concerning Regulatory Status of DIAMOND Series Lasers

This laser component does not include all safety features that are required by the United States Food and Drug Administration (FDA), Center for Devices and Radiological Health (CDRH) in laser systems sold to end users. It is sold solely to qualified manufacturers who in their end product, supply interlocks, indicators, and other required safety features, in full compliance with 21 CFR 1040, Subchapter J and/or other applicable national and local regulations.

1.5 Notice Concerning Warranty

Operation or handling of this laser component, inconsistent with this manual, may void the warranty.

1.6 The Preinstallation Manual

This preinstallation manual is designed to familiarize the user with the C-60+ Series system and its designated use. It contains important information on how to install the laser system safely, properly, and most efficiently. Observing these instructions helps to avoid danger, reduce repair costs, and downtimes and increase the reliability and lifetime of the laser system.

This manual describes the physical hazards related to the laser system, the means of protection against these hazards, and the safety features incorporated in the design of the laser system.

1.6.1 Intended Audience

The preinstallation manual is intended for all persons that are to work on or with the laser system.

1.6.2 Numbering of Sections, Pages, and Instructions

The sections are numbered continuously. The name of the section appears in the upper outside corner of every odd page. Each section ends with an even page number. Consequently, certain even pages at the ends of sections will be intentionally left blank.

The pages of this manual are numbered continuously by section. The page number appears in the bottom center of every page.

Each step within a procedure is sequentially numbered. Each procedure starts with the step number one.

1.6.3 Cited Standards

Unless otherwise stated, all technical standards cited in this manual relate to the latest version of the standard that is applicable at the date of the publication of this manual.

This information is in compliance with the Performance Standards for Laser Products, ' *United States Code of Federal Regulations*, 21 CFR 1040.10(d). In many cases, the international standards (ISO and IEC standards) have been adopted wholly or in part by national or regional standards authorities and are known locally under the designation assigned by this authority. For instance, the IEC 60825-1 has been adopted by the European Committee for Standardization as the standard EN 60825-1 and, in turn, by various national standards authorities as standards such as DIN EN 60825 (Germany) and BS EN 60825 (United Kingdom). The exact content, number and revision date of the national standard may, however, vary from that of the corresponding international standard. For further information, contact the publisher of the respective national standard.

1.7 Units of Measurements

In this manual, units of measurement are used according to the metric system (international system of units (SI)), e.g. meter, millimeter, square meter, cubic meter, liter, kilogram, bar, pascal; and imperial system, e.g. tons, pounds, and ounces; gallons and quarts; miles, yards, feet, and inch.

Temperatures are primarily indicated in degrees Celsius (°C) and Fahrenheit (°F).

The water hardness is indicated in parts per million (ppm; American Hardness).

1.8 Feedback Regarding Documentation

If there are any comments regarding the documentation provided, contact the Coherent Documentation Department.

In any correspondence, provide the following:

- the document part number, revision, and date of issue,
- the section number, page number and, where applicable, the procedure step number,
- a description of any errors,
- a proposal for improvements.

1.8.1 Feedback Address

Email documentation.support@coherent.com

Post Coherent Inc
Documentation and Training Development Department
5100 Patrick Henry Drive
Santa Clara, CA. 95054
USA

2

LASER SAFETY



This user information is in compliance with the following standards for Light-Emitting Products IEC 60825-1 / EN 60825-1 “*Safety of laser products - Part 1: Equipment classification and requirements*” 21 CFR Title 21 Chapter 1, Subchapter J, Part 1040 “*Performance standards for light-emitting products*”.

**WARNING!**

LASER RADIATION - AVOID EYE OR SKIN EXPOSURE TO DIRECT OR SCATTERED RADIATION CLASS 4 LASER PRODUCT!

**WARNING!**

Use of controls or adjustments or performance of procedures other than those specified herein may result in hazardous radiation exposure.

This laser safety section must be reviewed thoroughly prior to operating the C-60+ Series Air and Liquid-Cooled lasers. Safety instructions presented throughout this manual must be followed carefully.

2.1

Hazards

Hazards associated with lasers generally fall into the following categories:

- Biological hazards from exposure to laser radiation that may damage the eyes or skin
- Electrical hazards generated in the laser power supply or associated circuits
- Chemical hazards resulting from contact of the laser beam with volatile or flammable substances, or released as a result of laser material processing

The above list is not intended to be exhaustive. Anyone operating the laser must consider the interaction of the laser system with its specific working environment to identify potential hazards.

2.1.1 Optical Safety

Laser light, because of its optical qualities, poses safety hazards not associated with light from conventional light sources. The safe use of lasers requires all operators, and everyone near the laser system, to be aware of the dangers involved. Users must be familiar with the instrument and the properties of coherent, intense beams of light.

The safety precautions listed below are to be read and observed by anyone working with or near the laser. At all times, ensure that all personnel who operate, maintain or service the laser are protected from accidental or unnecessary exposure to laser radiation exceeding the accessible emission limits defined in the laser safety standards.



WARNING!

Direct eye contact with the output beam from the laser may cause serious eye injury and possible blindness.

The greatest concern when using a laser is eye safety. In addition to the main beam, there are often many smaller beams present at various angles near the laser system. These beams are formed by specular reflections of the main beam at polished surfaces such as lenses or beamsplitters. While weaker than the main beam, such beams may still be sufficiently intense to cause eye damage.

Laser beams are powerful enough to burn skin, clothing, or combustible materials, even at some distance. They can ignite volatile substances such as alcohol, gasoline, ether, and other solvents, and can damage light-sensitive elements in video cameras, photomultipliers, and photodiodes. The user is advised to follow the control measures below.

2.1.1.1 Recommended Precautions and Guidelines

1. Observe all safety precautions in the preinstallation and operator's manuals.
2. Always wear appropriate eyewear for protection against the specific wavelengths and laser energy being generated. See "Laser Safety Eyewear" on page 1-3. for additional information.
3. Avoid wearing watches, jewelry, or other objects that may reflect or scatter the laser beam.
4. Stay aware of the laser beam path, particularly when external optics are used to steer the beam.
5. Provide enclosures for beam paths whenever possible.

6. Block the beam before applying tools such as Allen wrenches or ball drivers to external optics.
7. Limit access to the laser to trained and qualified users who are familiar with laser safety practices. When not in use, lasers should be shut down completely and made off-limits to unauthorized personnel.
8. Terminate the laser beam with a light-absorbing material. Laser light can remain collimated over long distances and therefore presents a potential hazard if not confined. It is good practice to operate the laser in an enclosed room.
9. Post laser warning signs in the area of the laser beam to alert those present.
10. Exercise extreme caution when using solvents in the area of the laser.
11. Never look directly into the laser light source or at scattered laser light from any reflective surface, even when wearing laser safety eyewear. Never sight down the beam.
12. Set up the laser so that the beam height is either well below or well above eye level.
13. Avoid direct exposure to the laser light. Laser beams can easily cause flesh burns or ignite clothing.
14. Advise all those working with or near the laser of these precautions.

2.1.1.2

Laser Safety Eyewear

Always wear appropriate laser safety eyewear for protection against the specific wavelengths and laser energy being generated. The appropriate eye protection can be calculated as defined in the “EN 207 Personal eye protection equipment - Filters and eye-protectors against laser radiation (laser eye-protectors)”, in other national or international standards (e.g. ANSI, ACGIH, or OSHA) or as defined in national safety requirements. Anyone working with or near the C-60+ Series laser must wear laser safety eyewear with an OD rating 5 eye protection.



CAUTION!

Laser safety eyewear protects the user from accidental exposure to laser radiation by blocking light at the laser wavelengths. However, laser safety eyewear may also prevent the operator from seeing the beam or the beam spot. Exercise extreme caution even while wearing safety glasses.

2.1.1.3 Viewing Distance

The C-60+ Series laser produces optical power levels that are dangerous to the eyes and skin if exposed directly or indirectly. These products must be operated only with proper eye and skin protection at all times. Never view directly emitted or scattered radiation with unprotected eyes. When viewing the laser during operation, the operator must maintain the Nominal Ocular Hazard Distance (NOHD) between the laser or scattered radiation and the operator's eyes. Figure 2-1 summarizes the NOHD for the power range of the C-60+ Series for direct viewing of the collimated beam along with two other common configurations. The NOHD in Figure 2-1 is based on the Maximum Permissible Exposure (MPE = 0.1 W/cm²) level for each power condition as specified in ANSI Z136.1 and IEC 60825-1.

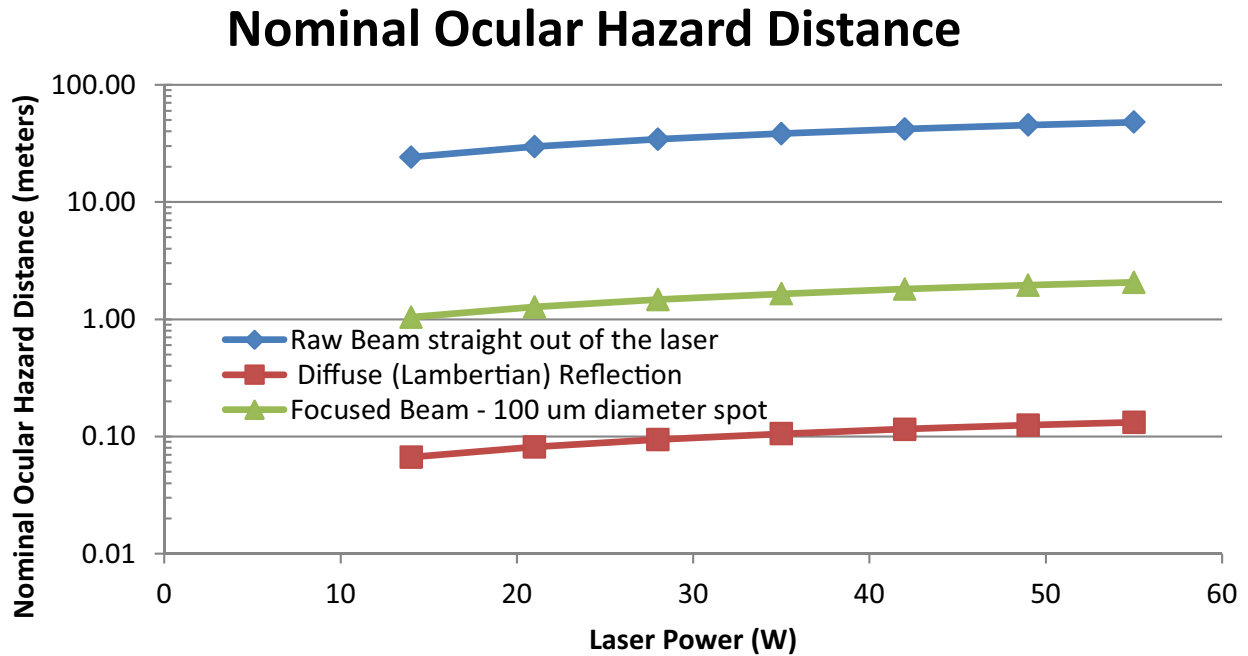

Figure 2-1. Nominal Ocular Hazard Distance (NOHD) for indicated conditions calculated per ANSI Z136.1 and IEC 60825-1

2.1.2 Electrical Safety

The C-60+ Series uses AC and DC voltages. There are no user serviceable components in the laser and integrated RF power module. All units are designed to be operated as assembled. Warranty will be voided if the laser head is disassembled.



DANGER!

To avoid potentially fatal electrical shock hazards from electrical equipment, follow all applicable electrical codes such as (in the U.S.) the National Electrical Code.

2.1.2.1 Recommended Precautions and Guidelines

The following precautions must be observed by everyone when working with potentially hazardous electrical circuitry:



DANGER!

When working with electrical power systems, the rules for electrical safety must be strictly followed. Failure to do so could result in the exposure to lethal levels of electricity.

1. Disconnect main power lines before working on any electrical equipment when it is not necessary for the equipment to be operating.
2. Do not short or ground the power supply output. Protection against possible hazards requires proper connection of the ground terminal on the power cable, and an adequate external ground. Check these connections at the time of installation, and periodically thereafter.
3. Never work on electrical equipment unless there is another person nearby who is familiar with the operation and hazards of the equipment, and who is competent to administer first aid.
4. When possible, keep one hand away from the equipment to reduce the danger of current flowing through the body if a live circuit is touched accidentally.
5. Always use approved, insulated tools.

2.2 Safety Features and Compliance with Government Requirements

The following features are incorporated into the instrument to conform to several government requirements:

United States of America:

The applicable United States Government requirements are contained in 21 CFR, Subchapter J, Part 1040 administered by the Center for Devices and Radiological Health (CDRH).

Integrators who incorporate a C-60+ Series laser into other products that they introduce into United States commerce are defined in the law as manufacturers who are thus required to manufacture their products to conform to the Federal standard, certify them, and submit product reports to the CDRH.

For jurisdictions outside of the United States, it is the responsibility of the buyer of this laser device to ensure that it meets the local laser safety requirements.

Europe:

The European Community requirements for product safety are specified in the Low Voltage Directive (LVD) (published in 2014/35/EU). The Low Voltage Directive requires that lasers comply with the standard EN 61010-1/IEC 61010-1 "Safety Requirements For Electrical Equipment For Measurement, Control, and Laboratory Use" and EN 60825-1/IEC 60825-1 "Safety of Laser Products". Compliance of this laser with the European requirements is certified by the CE mark.

2.2.1 Laser Classification

Governmental standards and requirements specify that the laser must be classified according to the output power or energy and the laser wavelength. The C-60+ Series is classified as Class 4 based on 21 CFR, Subchapter J, Part 1040, section 1040.10 (c) and/or IEC/EN 60825-1:2007, Clause 8 and IEC/EN 60825-1:2014, Clause 4. In this manual, the classification will be referred to as Class 4.

2.2.2 Protective Housing

The laser head is enclosed in a protective housing that prevents human access to radiation in excess of the limits of Class radiation as specified in the 21CFR, Part 1040 Section 1040.10 (f)(1) and EN 60825-1/IEC 60825-1 Clause 6.2 except for the output beam, which is Class 4.

2.2.3 Protective Covers (Safety Interlocks)

The RF power module and laser head covers are not interlocked. These covers should never be removed. There are no user-serviceable components inside.



WARNING!

Use of controls or adjustments, or performance of procedures other than those specified herein, may result in hazardous radiation exposure.



DANGER!

To avoid potentially fatal electrical shock hazards from electrical equipment, follow all applicable electrical codes such as (in the U.S.) the National Electrical Code.

2.3 Compliance to Standards Relevant to CE Mark

C-60+ Series lasers are OEM products, and are sold as components for integration into complete laser systems by a system integrator. These products are tested and CE Marked as independent products. For specific details regarding what applicable compliance directives and standards the products have been tested to, refer to the Declaration of Conformity which is available upon request from Coherent, per contact information on p. ii of this manual.

Compliance to applicable standards for a particular laser tool incorporating C-60+ Series lasers must be demonstrated by the manufacturer of the complete system. The primary issue for the system integrator is to design covers, shielding, grounding, routing of electrical cable assemblies, and control elements with the proper safety features so that during subsequent testing the system meets the appropriate standards.

2.4 Environmental Compliance

This section describes compliance with various environmental regulator directives to identify hazardous substances.

2.4.1 Electromagnetic Compatibility

Compliance of this laser with the Electromagnetic Compatibility (EMC) requirements is certified by the CE mark. For more information about the CE mark see “Compliance to Standards Relevant to CE Mark” (p. 15).

Each application and installation is unique, and in some cases, the user may experience Electromagnetic Interference (EMI) noise being emitted from various electronic components. This laser uses high-frequency RF (100 MHz). While adequate countermeasures have been taken to suppress this emission to meet the requirements stated on the Declaration of Conformity, the user may wish to employ additional measures to suppress the EMI to reduce the emissions further. Standard methods of reducing the EMI are:

1. Use of shielded control cables grounded on both ends
2. Addition of appropriate ferrite beads to cables connected to the beam source

2.4.2 RoHS Compliance

The RoHS directive restricts the use of certain hazardous substances in electrical and electronic equipment. Coherent can provide RoHS certification upon request for products requiring adherence to the RoHS Directive.

2.4.3 China RoHS Compliance

Coherent products supplied by Coherent are in conformity with applicable requirements of China's “Management Methods”, commonly referred to as China RoHS, and associated standards and applies to the production, sale, and import of products in the People's Republic of China.

The China RoHS Regulation requires that the Environment-Friendly Use Period (EFUP) symbol be displayed on any product. This symbol indicates an environment-friendly use period with the number of years inside the circle (Figure 2-2).

This regulation also requires that the date of manufacture be identified (in Chinese characters) on the product label (Figure 2-3).

The China RoHS Hazardous Substance Marking Table is located in the shipping document packet shipped with the product (or laser system).

2.4.5 Waste Electrical and Electronic Equipment (WEEE)

The European Waste Electrical and Electronic Equipment (WEEE) Directive (2012/19/EU) is represented by a crossed-out waste material container label. The purpose of this directive is to minimize the disposal of WEEE as unsorted municipal waste and to facilitate its separate collection.

The WEEE Directive applies to this product and any peripherals marked with this symbol. Do not dispose of these products as unsorted municipal waste. Contact the local distributor for procedures for recycling this equipment.

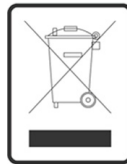
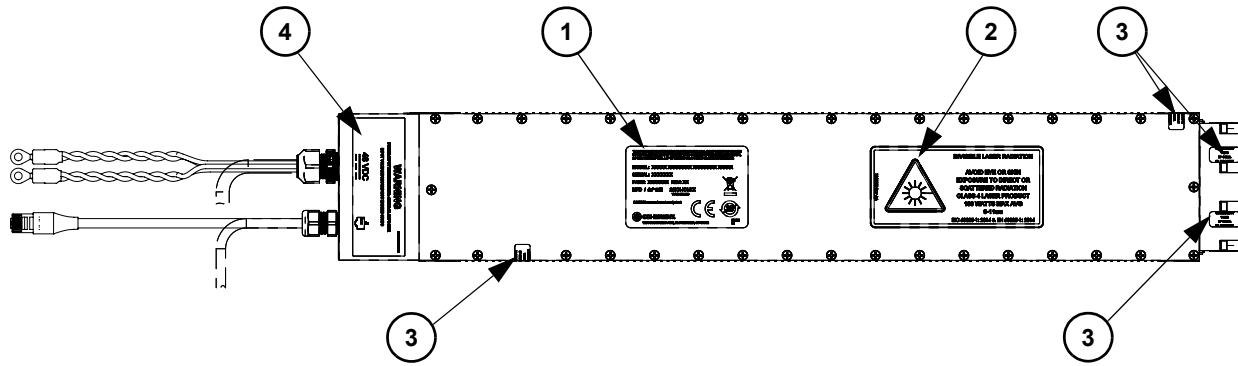

Figure 2-4. Waste Electrical and Electronic Equipment Label

2.5 Labeling

Refer to Figure 2-5, “Location of Safety Labels for Air-Cooled Lasers,” (p. 19) and Figure 2-6, “Location of Safety Labels for Liquid-Cooled Lasers,” (p. 21) for the location of all required safety labels and Figure 2-7 (p. 22) for a description. These include warning labels indicating removable or displaceable protective housings, apertures through which laser radiation is emitted, and labels of certification and identification [21 CFR § 1040.10(g), 21 CFR § 1010.2, and 21 CFR § 1010.3/ EN 60825-1/IEC 60825-1, Clause 7].



Air-Cooled Top View

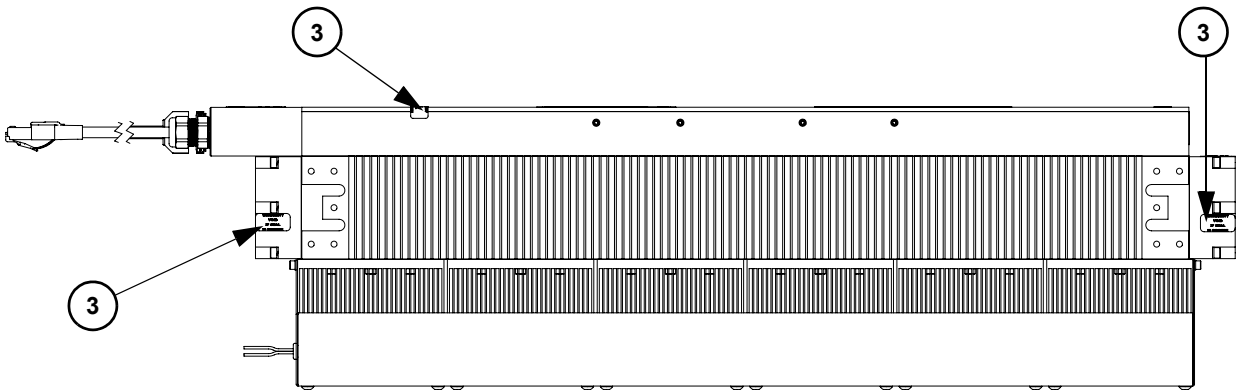

Air-Cooled Side View (with Fans)

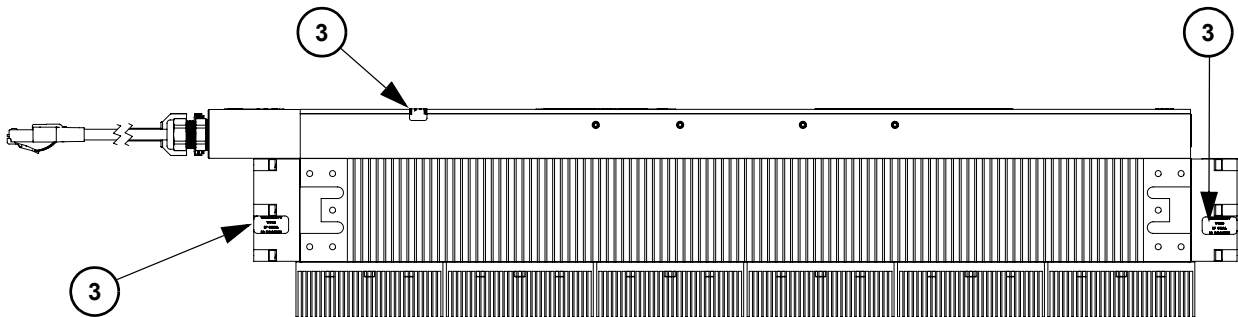

Air-Cooled Side View (Cross Flow)

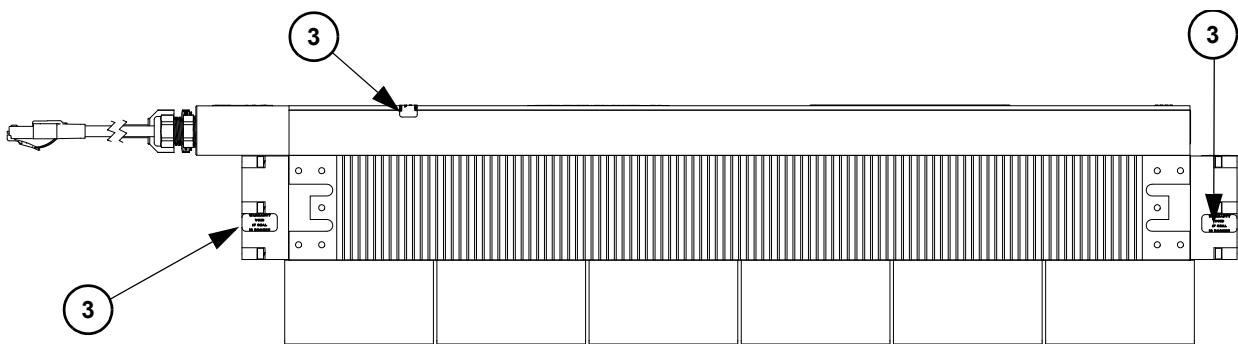

Air-Cooled Side View (Axial Flow)

Figure 2-5. Location of Safety Labels for Air-Cooled Lasers (Sheet 1 of 2)

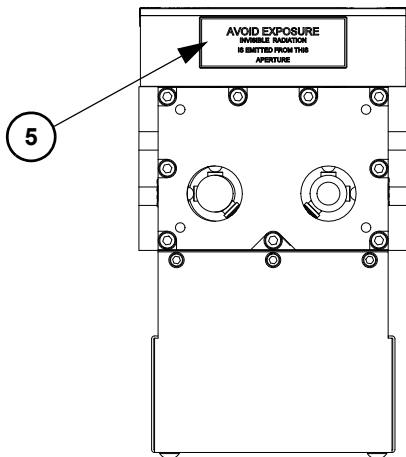

Air-Cooled Front View (with Fans)

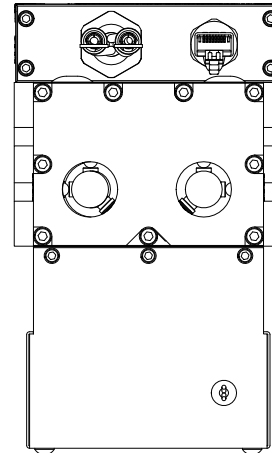

Air-Cooled Back View (with Fans)

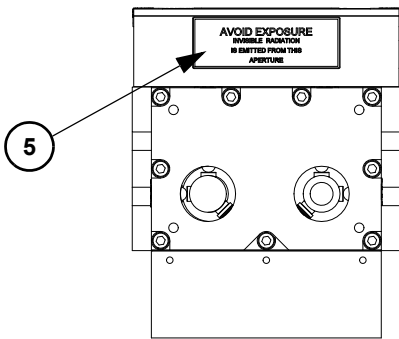

Air-Cooled Front View (Cross Flow)

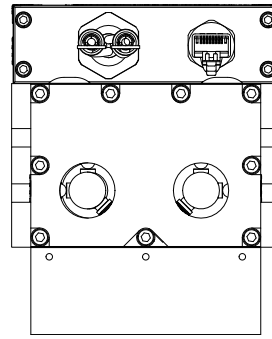

Air-Cooled Back View (Cross Flow)

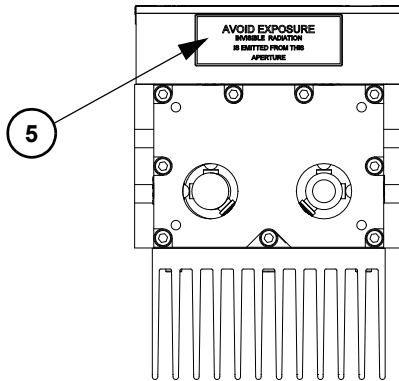

Air-Cooled Front View (Axial Flow)

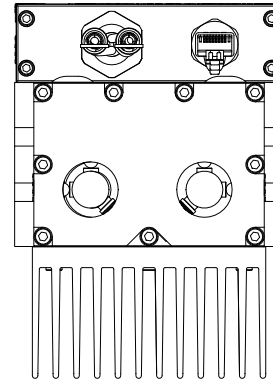

Air-Cooled Back View (Axial Flow)

Figure 2-5. Location of Safety Labels for Air-Cooled Lasers (Sheet 2 of 2)

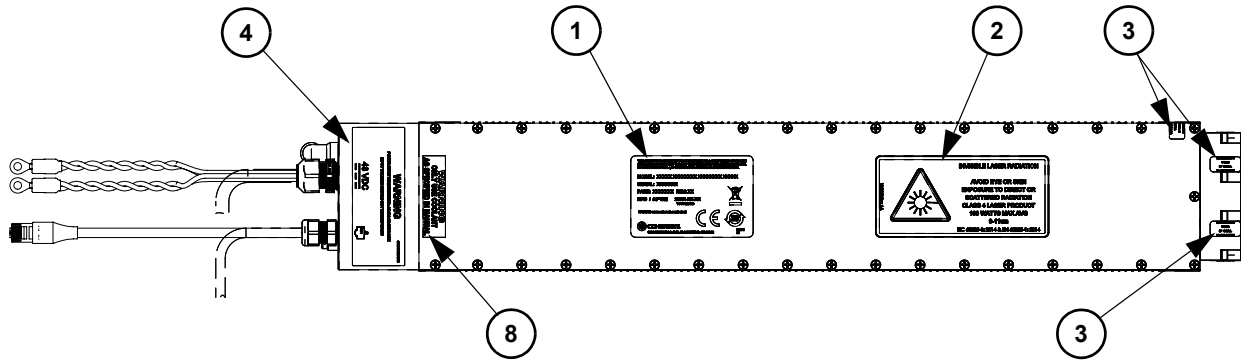

Liquid-Cooled Top View

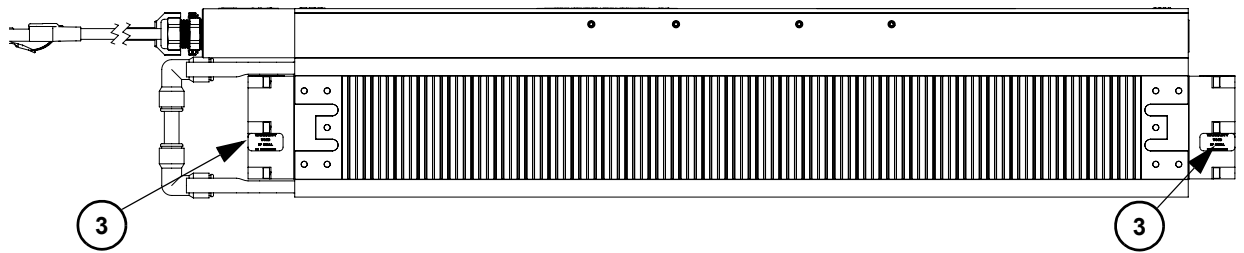

Liquid-Cooled Side View

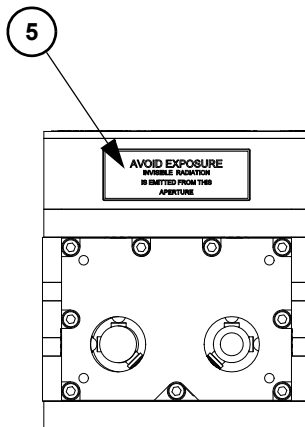

Liquid-Cooled Front View

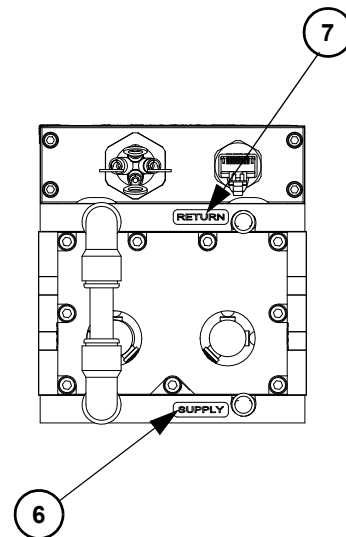

Liquid-Cooled Back View

Figure 2-6. Location of Safety Labels for Liquid-Cooled Lasers

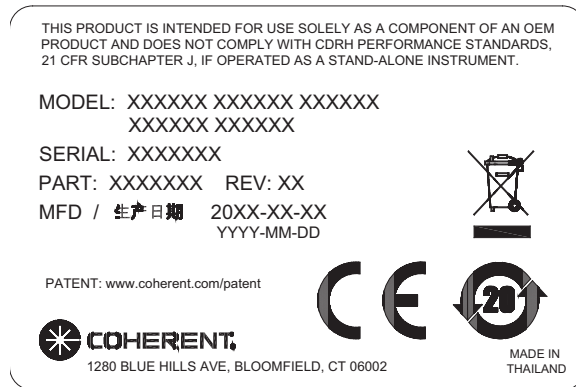

1. Identification Label

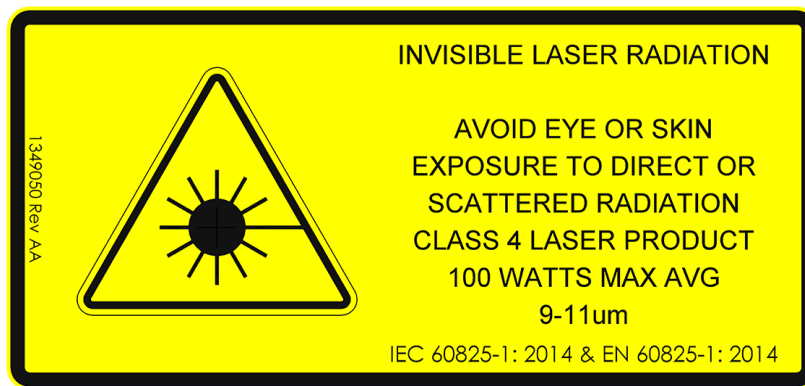

2. Danger of Laser Radiation Label



3. Tamper Proof Label

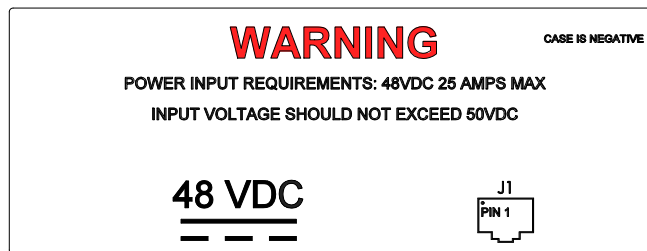

4. Voltage Warning Label

Figure 2-7. Labels



5. Warning Aperture Label



6. Coolant Supply Label (Liquid-Cooled Only)



7. Coolant Return Label (Liquid-Cooled Only)



8. Coolant Warning (Liquid-Cooled Only)

Figure 2-7. Labels

2.6 Sources of Additional Information

The following are sources for additional information on laser safety standards and safety equipment and training.

2.6.1 Laser Safety Standard

American National Standard for Safe Use of Lasers
ANSI Z136 Series
American National Standards Institute (ANSI)
www.ansi.org

Performance standards for light-emitting products
21 CFR Title 21 Chapter 1, Subchapter J, Part 1040
U.S. Food and Drug Administration
www.fda.gov

2.6.2 Publications and Guidelines

International Electrotechnical Commission (IEC)
www.iec.ch

A Guide for Control of Laser Hazards
American Conference of Governmental
and Industrial Hygienists (ACGIH)
www.acgih.org

Laser Safety Guide
Laser Institute of America
www.lia.org

3 DESCRIPTION AND SPECIFICATIONS

3.1 Introduction

In this section, specifications and characteristics of the C-60+ Series laser will be discussed. Characteristics to be discussed include mechanical, thermal, electrical, and optical interfaces; and environmental requirements and limitations.

The C-60+ Series laser is a sealed-off, RF-excited CO₂ lasers, capable of continuous wave (CW) or modulated operation. From the laser safety point of view, this laser is considered to be a component and must be integrated into a system by a qualified original equipment manufacturer (OEM) prior to delivery to the end user. See “Safety Features and Compliance with Government Requirements” (p. 14) for a complete discussion of laser safety issues.

3.2 Purpose of This Manual

This manual is designed to assist the original equipment manufacturer (OEM) during the integration of the C-60+ Series OEM laser. It contains information on the performance and operation of the laser as well as installation and control methods.

3.3 Configuration

Figure 3-1 on page 3-26 illustrates the baseline configurations (i.e., without any optional hardware additions or deletions) of the C-60+ Series laser. Each laser system consists of a laser head assembly and an integrated radio frequency (RF) power supply. The RF power module converts 48 VDC, ≤ 20 A power to radio frequency power.

Connection of the customer-supplied DC power supply to the C-60+ Series is via a barrier strip with screw terminals on the RF power module. These terminals should also be used for the connection of wires for remote voltage sensing. Such sensing is recommended to control the voltage at the input to the RF power module more precisely.

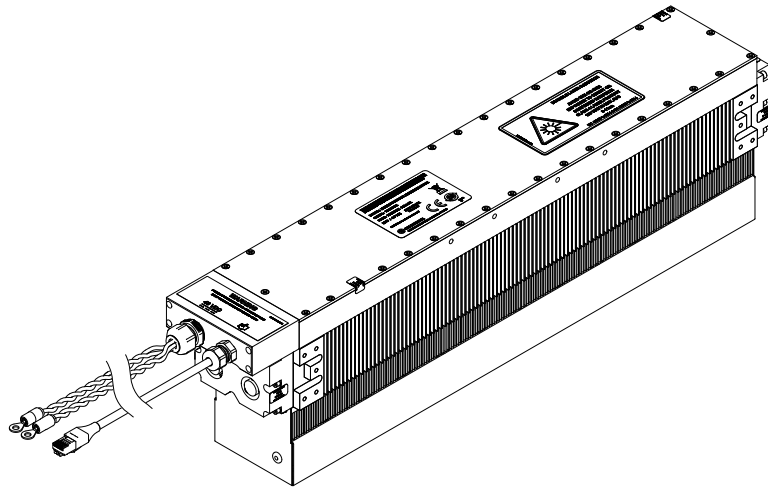

Air-Cooled with Fans

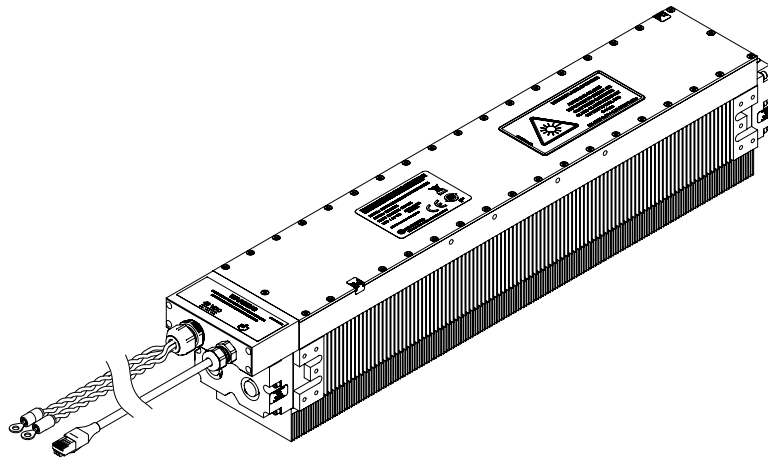

Air-Cooled Cross Flow

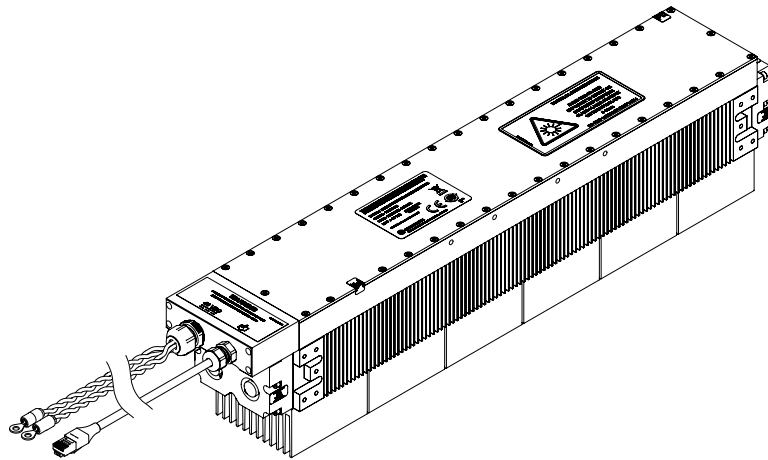

Air-Cooled Axial Flow

Figure 3-1. C-60+ Series Air-Cooled and Liquid-Cooled Lasers

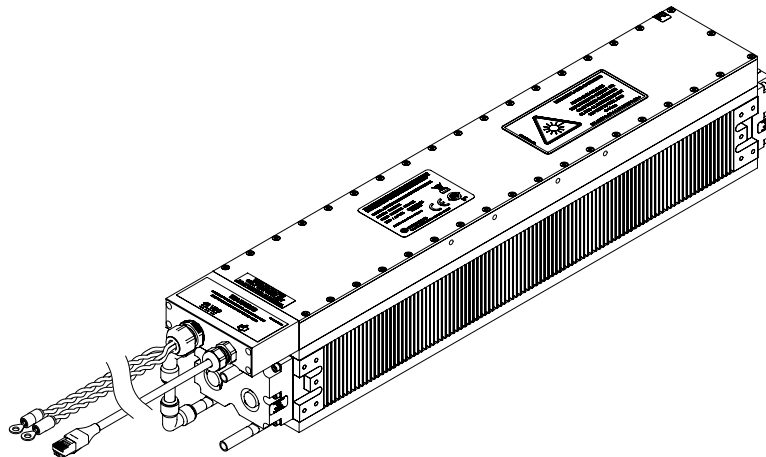

Liquid-Cooled

Figure 3-1. C-60+ Series Air-Cooled and Liquid-Cooled Lasers (Continued)

3.4 Hardware Overview

The C-60+ Series is a waveguide, carbon dioxide (CO₂) laser. RF electric fields provided by the RF power module excite the CO₂ gas mixture. The standard configuration of these lasers operates at wavelengths between 9 μm and 11 μm in the infrared region of the electromagnetic spectrum.

3.4.1 DC Input Power

DC input power is provided by the user through customer-supplied bus wiring, which goes to the RF power module. The RF power module converts this DC electrical power into RF power, which is used to excite the gas in the laser head. The DC power supply requirements are discussed in detail in the subsection entitled “DC Power Supply Requirements” (p. 53).

3.5 Cooling Requirements

Total heat dissipation for the laser is specified in Table 3-2 (p. 30). The laser head typically dissipates 650 W from its base surface while the RF power module typically dissipates 350 W for a total typical heat dissipation of 1000 W (maximum total heat dissipation is < 1200 W). The C-60+ Series must be provided adequate cooling to keep the laser operating temperature within acceptable limits. The cooling method that is used must not induce stresses that will result in misalignment of the laser resonator. The C-60+ Series heat sinks are designed so that the assembled structure remains free of excessive stress. Installation requirements related to cooling of the air-cooled version of the C-60+ Series lasers are discussed in detail in the subsection entitled “Air Cooling” (p. 42).

3.5.1 Comparison of Air Cooling & Liquid Cooling (Reference)

Air cooling and liquid cooling each have distinct advantages. Table 3-1 describes the factors to be taken into consideration when choosing a cooling system for a laser module.

Consideration should also be taken if condensable vapors are present and to take suitable measures to purge sensitive areas, such as optical surfaces, with a suitable gas.

Table 3-1. Comparison: The Benefits of Air Cooling vs. Liquid Cooling Methods

Air Cooling	Liquid Cooling
<ul style="list-style-type: none"> • Low in cost • Low in complexity • Low service requirements • Easier to install 	<ul style="list-style-type: none"> • Offers the highest process stability • Can yield the most compact arrangement • Suitable for applications in which the ambient air temperature exceeds 40°C • Better for applications in which the ambient air is laden with particulates • Easier to make a hermetically sealed system



NOTICE!

To avoid damage to the laser, never operate the laser without a supply of cooling water meeting the requirements indicated in Table 3-2 or adequate air cooling.

3.5.2 Liquid Cooling Option of the C-60+ Series

Installation requirements related to the liquid cooling option of the C-60+ Series lasers are discussed in detail in “Liquid Cooling” (p. 43). This section is a quick overview only. Table 3-2 shows the recommended connection from the customer-supplied refrigerated recirculator to the C-60+ Series laser systems.

Coherent recommends that the coolant water flowing from the customer-supplied refrigerated recirculator flow to the laser head, then to the RF power module. Although not shown in Figure 3-2 on page 29, a flow interlock device must be provided by the customer in the cooling-water-return line to detect the presence of cooling water with the required flow rate, and to shut down the laser if adequate coolant flow is not present.

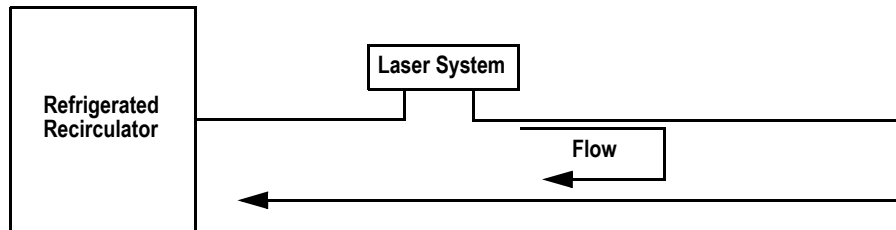

Figure 3-2. Cooling System Diagram

3.6 Laser Head

The laser head takes RF input power and converts some of it to laser radiation. The rest of the RF input power is exhausted as waste heat. For the C-60+ Series air-cooled lasers, the waste heat is exhausted into the ambient air. In C-60+ Series liquid-cooled lasers, this waste heat is exhausted into the liquid cooling water which flows through the laser head. The laser head consists of the folded optical waveguide resonator, the all-metal gas envelope structure, and RF power module. Infrared laser radiation is emitted from the optical aperture. Pictures and dimensional drawings for the C-60+ Series lasers are shown in Figure 3-1 (p. 26).

3.7 RF Power Module

The C-60+ Series RF power module converts DC input power to RF energy, which is sent to the laser head. Heat from the RF power module is exhausted into the surrounding air or liquid cooling water. An RJ-45-type connector is used to control the laser system. All of the user interfaces (DC power, cooling water, and signal interface) are on one panel of the RF power module.

3.8 Configuration and Facility Requirements

Table 3-2 describes the configuration and facility requirements for the C-60+ Series laser. Laser performance specifications are provided on the data sheet available on line at www.coherent.com and in the test report provided with the laser.

Table 3-2. C-60+ Series Configuration and Facility Requirements

Parameter	Value
Weight ¹	
Air-Cooled, Axial Flow	10.0 kg (22.0 lbs.)
Air-Cooled, Cross Flow, with Fans	10.4 kg (23.0 lbs.)
Air-Cooled, Cross Flow without Fans	9.8 kg (21.5 lbs.)
Liquid-Cooled	10.8 kg (23.8 lbs.)
Dimensions LxWxH ²	
Air-Cooled, Axial Flow	638 x 93 x 129 mm (25.1 x 3.7 x 5.1 in.)
Air-Cooled, Cross Flow, with Fans	638 x 93 x 155 mm (25.1 x 3.7 x 6.1 in.)
Air-Cooled, Cross Flow without Fans	638 x 93 x 114 mm (25.1 x 3.7 x 4.5 in.)
Liquid-Cooled	638 x 93 x 103 mm (25.1 x 3.7 x 4.1 in.)
IP Rating	IP65
Input Power	
Input Voltage	48 VDC ± 2% regulation,

Table 3-2. C-60+ Series Configuration and Facility Requirements (Continued)

Parameter	Value
Input DC current	21 A (50 A peak for 1 ms minimum, measured at input terminals)
Cooling	Air or Liquid
Heat Dissipation (W)	≤850
Maximum Case Temperature	< 60°C (140°F)
Operating Environment	
Temperature	5°C to 50°C (41°F to 122°F)
Altitude	≤ 2,000 m (≤ 6,500 ft.)
Humidity	Non-condensing ≤ 95%
Shipping/Storage Environment	-10°C to 60°C (14°F to 140°F), Non-condensing
Liquid Cooling Option	
Coolant Composition	Anti-Corrosion Treated Water
Coolant Temperature Range	15 to 30°C (59 to 86°F)
Coolant Inlet Temperature Variation	± 1.0°C
Coolant Flow Rate	> 3.8 lpm (1.0 gpm)
Minimum Coolant Differential Pressure Required	206 kPa (30psi)
Coolant Max Static Pressure	827 kPa (100 psig)
¹ Weighed on production floor ² Includes clearance for cables	

4 UTILITY REQUIREMENTS AND SYSTEM INSTALLATION

4.1 Introduction

This section covers unpacking and installation of the C-60+ Series lasers. Detailed operating instructions are given in “Laser Operation” (p. 57) in the operator’s manual.

4.2 Unpacking and Inspection

Before unpacking the laser components, inspect the shipping carton for evidence of rough handling, and note any damage. If damage to the shipping carton is evident, request the carrier’s agent be present when the unit is unpacked. Inform the shipping carrier and Coherent of any evidence of damage in shipment. The buyer and shipping carrier is responsible for any damage which occurs during shipment.

4.2.1 Verifying Delivery

The shipping container contains the following:

- Laser head and integral RF power module
- Final Test Sheet

If any of these items are missing, report this to Coherent immediately.

4.2.2 Protective Shipping Tape

The front of the C-60+ Series laser head is protected by a blue adhesive film or tape (see Figure 4-1). This tape is designed to protect the optics during shipping and must be removed prior to operating the laser.



NOTICE!

To avoid damage, the blue protective tape must be removed **BEFORE** operating the laser.



Figure 4-1. Protective Shipping Tape

4.2.2.1 Tape Removal

To remove the protective tape:

1. Pinch one corner of the tape between the thumb and index fingers.
2. Gently pull the tape off of the laser.
3. Discard the tape and do not place the tape anywhere near or on the laser.

4.3

Safety Issues in Laser Installation

Installation of the C-60+ Series lasers must comply with all applicable electrical safety and laser safety laws and regulations. Review “Laser Safety” (p. 9) for important information relating to safety.

The negative (return) side of the DC input connection to the C-60+ Series RF power module is connected internally to the chassis. The user must assure that the system into which the C-60+ Series is built protects against the possibility that the C-60+ Series laser head or RF power module chassis could be at a hazardous voltage and that personnel could be exposed to these voltages.



DANGER!

To avoid potentially fatal electrical shock hazards from electrical equipment, follow all applicable electrical codes such as (in the U.S.) the National Electrical Code.

The laser must be secured properly to avoid the possibility of the laser shifting unexpectedly during operation, creating a hazardous condition. The location of the output beam of the C-60+ Series laser head is shown in Figure 4-2 (p. 36). The laser output is emitted from the aperture shown in the referenced figure and propagates within a full cone angle up to 5°. The acceptance angle of the system aperture must intercept all of the output of the laser.

It is also extremely important to understand the direction, divergence, and magnitude of all reflections that will occur from optical surfaces. Infrared (IR) beams, such as those from the C-60+ Series lasers, can also be located with commercially available IR screens, such as those produced by Macken Instruments, Inc. [tel. (707) 566-2110]. Coherent recommends that all beam propagation paths be enclosed and that personnel operating the laser be qualified optical technicians who are familiar with this type of hardware.

4.4 Mechanical Mounting

The dimensions for the C-60+ Series laser heads are shown in Figure 4-2. Mechanical mounting of the C-60+ Series laser head must result in no distortion or stress the laser head in any way. Otherwise, optical alignment and power stability could be adversely affected.

NOTES:

1. ACCESSORY MOUNT MAX LOAD 2.3 KG [5 LB] AT 254 mm [10 in.] OR EQUIVALENT.
2. DIMENSIONS SHOWN ARE FOR REFERENCE ONLY.

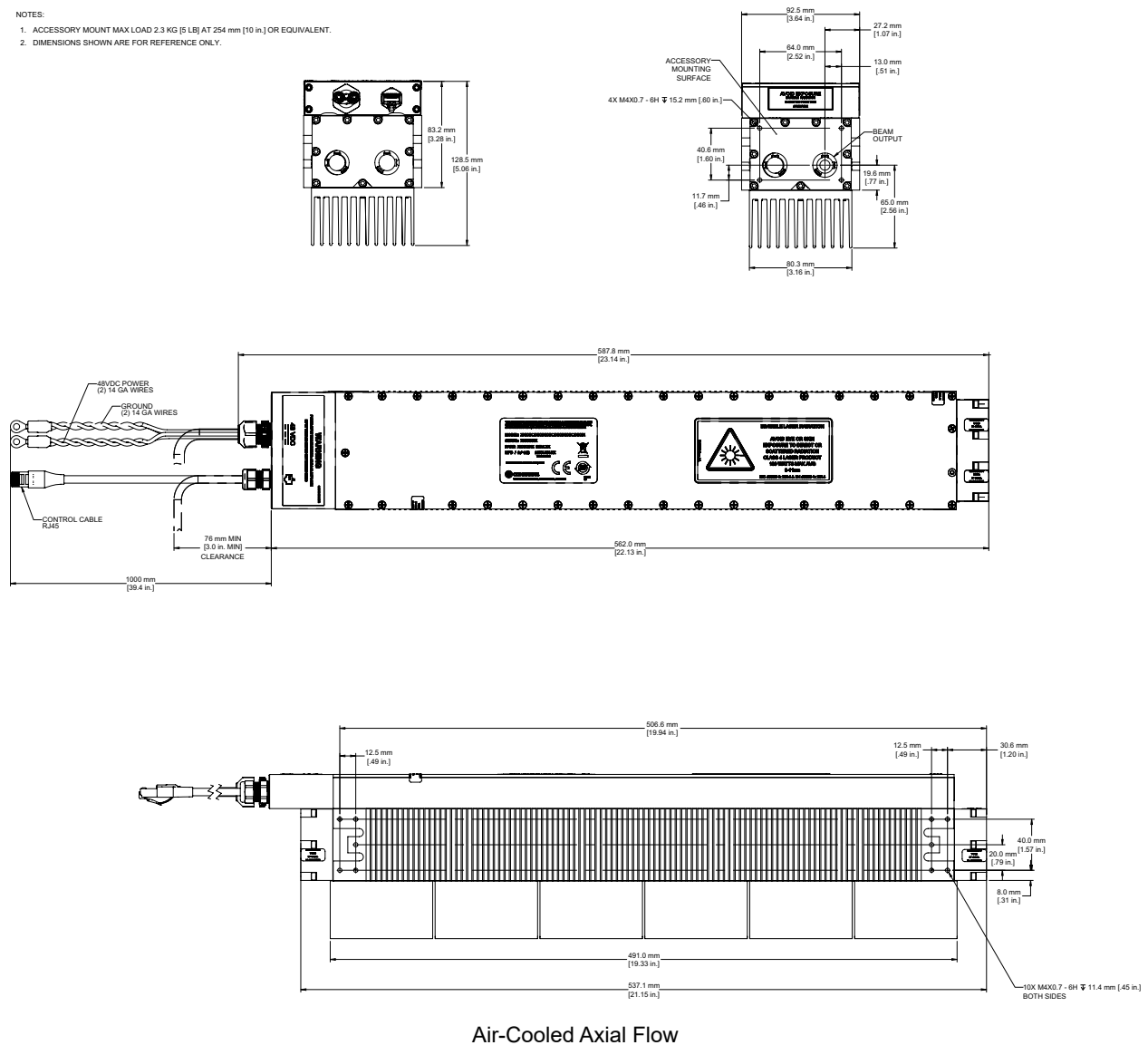

Figure 4-2. C-60+ Series Air-Cooled and Liquid-Cooled Laser Head Dimensions

Utility Requirements and System Installation

NOTES:

▲ MAINTAIN 60mm [2.4 in.] MINIMUM CLEARANCE AROUND COOLING FANS AS INDICATED FOR PROPER AIR FLOW.

2. ACCESSORY MOUNT MAX LOAD 2.3 KG [5 LB] AT 254 mm [10 in.] OR EQUIVALENT.

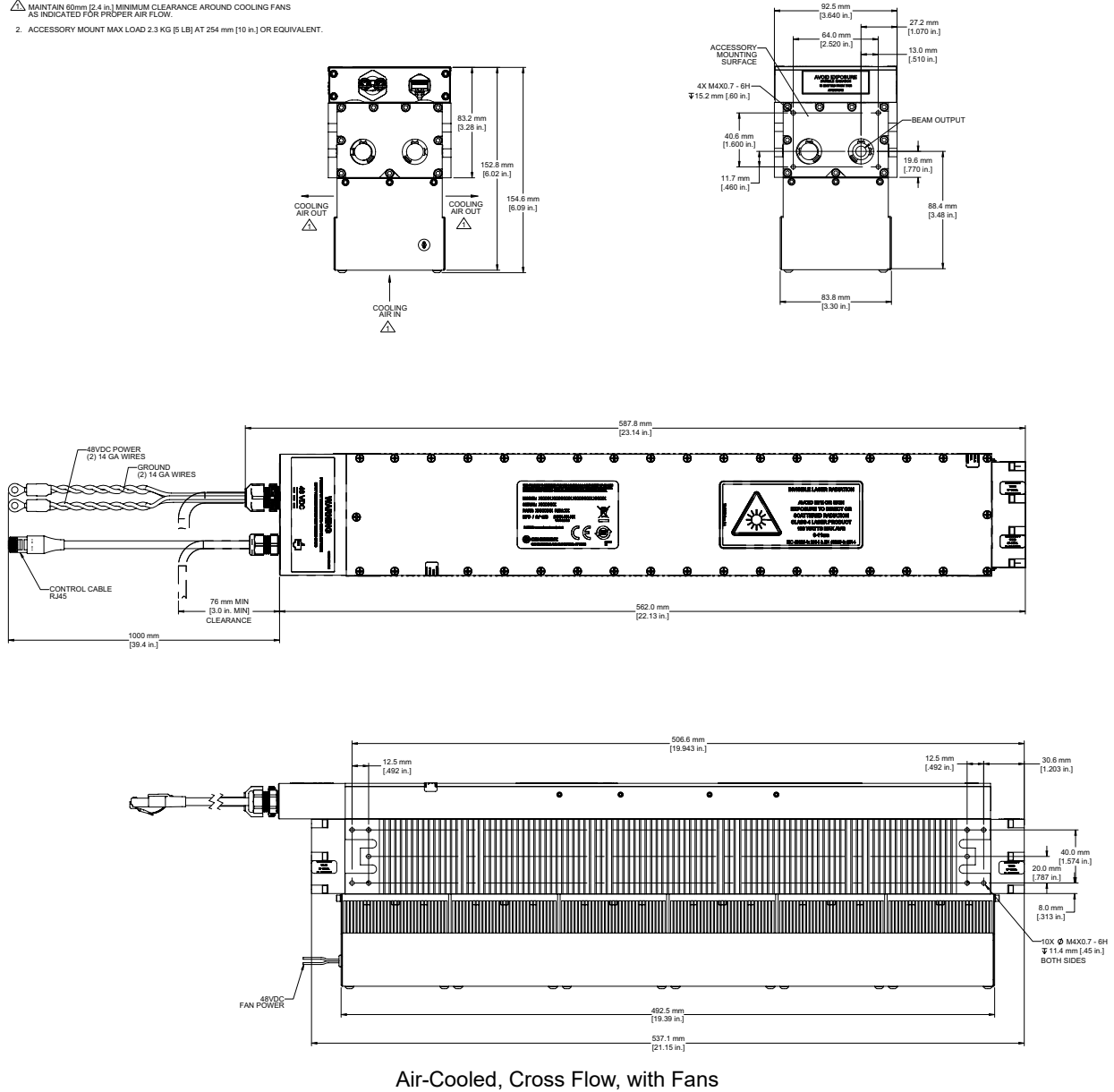

Air-Cooled, Cross Flow, with Fans

Figure 4-2. C-60+ Series Air-Cooled and Liquid-Cooled Laser Head Dimensions

DIAMOND C-60+ Series OEM Laser Preinstallation Manual

NOTES:

1. ACCESSORY MOUNT MAX LOAD 2.3 KG [5 LB] AT 254 mm [10 in.] OR EQUIVALENT.

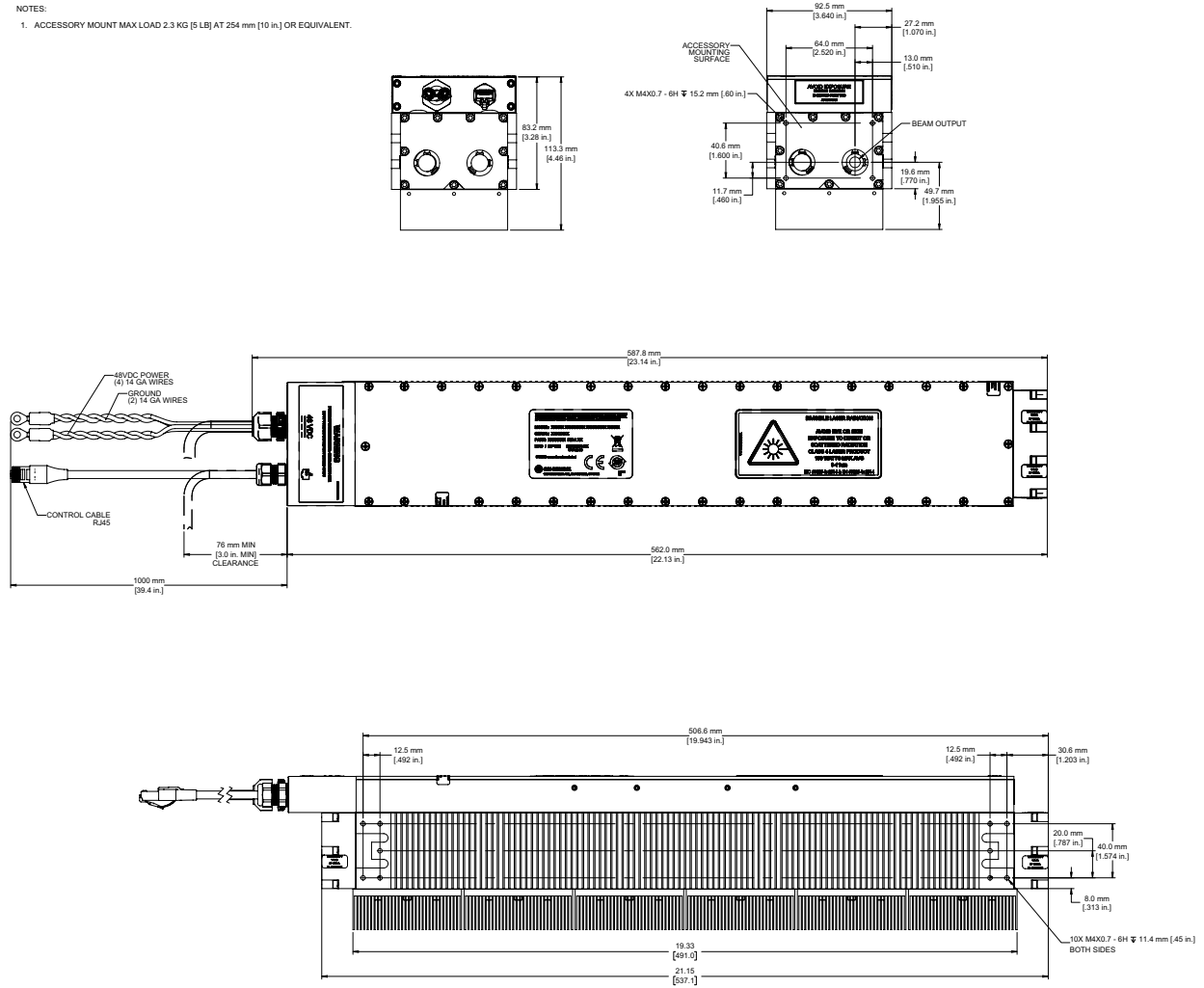

Air-Cooled, Cross Flow, without Fans

Figure 4-2. C-60+ Series Air-Cooled and Liquid-Cooled Laser Head Dimensions

Utility Requirements and System Installation

1. ACCESSORY MOUNT MAX LOAD 2.3 KG (5 LB) AT 254 mm (10 in.) OR EQUIVALENT.

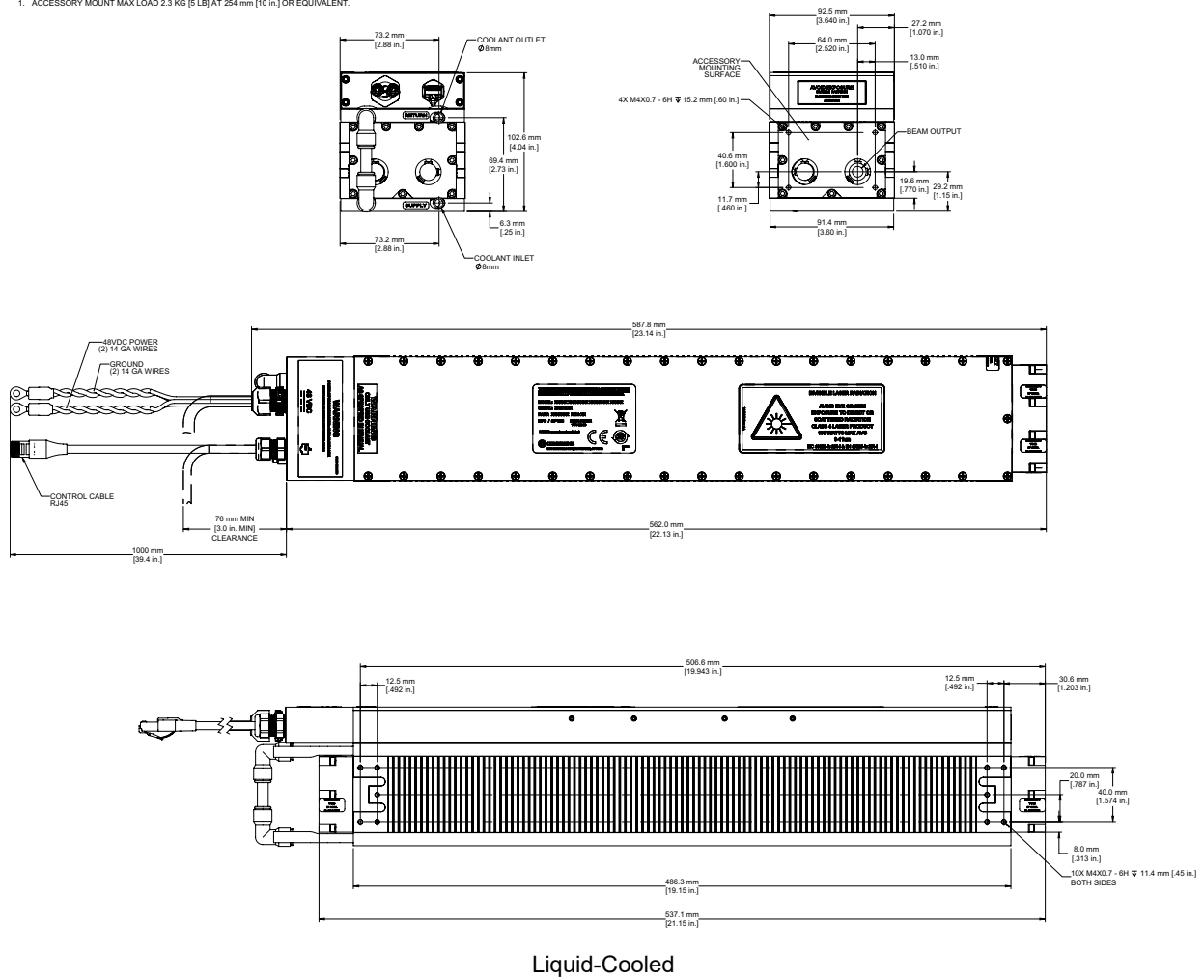

Liquid-Cooled

Figure 4-2. C-60+ Series Air-Cooled and Liquid-Cooled Laser Head Dimensions

4.4.1 Mounting Considerations for the C-60+ Series

Certain aspects of specific customer applications may preclude absolute interchangeability of laser heads. For example, for certain applications, the sensitivity of the application to optical beam pointing errors may require external optical realignment after the laser head is replaced in the customer's integrated system. Depending on the method of mounting and the sensitivity of the integrated customer system to beam pointing errors, even removing a laser head from the customer's system, then replacing the same laser head back into the customer's system may require external optical realignment. This external alignment would be a repositioning of the head itself or adjustment of beam delivery mirrors (positions and angle). Consult Coherent if there are any questions about such interchangeability issues.

Coherent recommends use of the optional brackets (part number 1101-12-0016 for a set of 4) that are designed for mounting the laser safely without inducing any stress onto the laser. Care must be taken not to induce stress onto the laser head, as optical mis-alignment of the laser resonator can occur, which would require the laser to be returned to Coherent for service. A mechanical drawing for this bracket is provided in "Parts List" (p. 75) in the operator's manual. Coherent strongly encourages use of this bracket or a similar design in order to accommodate temperature changes in operation while providing secure mounting.

4.5 Ambient Air Cleanliness

Do not turn the laser on if there is water, dust, or dirt on the output element; otherwise, damage to the coating on this optical element may occur. To prevent such optical damage, never allow the output window to become contaminated.

Do not allow the fins on the heat-sinking elements to become clogged with dirt, dust, or debris. They must be cleaned periodically as indicated in "Maintenance and Troubleshooting" (p. 71) in the operator's manual.

The Coherent warranty covers defects in material and workmanship relating to the output optical element, but this warranty does not cover damage to the external output optical surface which is the result of contamination of the surface or abrasion of the surface.

4.6 Ingress Protection (IP) Certification

The C-60+ Series laser has been tested in accordance with IEC 60529, Edition 2.1 *Degrees of Protection Provided by Enclosures*. If required, there are many resources available on the Internet to download a copy of the IEC 60529 standard.

The Ingress Protection rating system shows the degree of protection from both solids and liquids. The first number in this rating system indicates the protection from solids, (typically dust and airborne particulates) for the C-60+ Series laser. The second digit refers to protection against liquids. The C-60+ Series has been certified as complying with level IP65 of the standard. The descriptions for IP65 are stated below:

First Digit (6) No ingress of dust: complete protection against contact (dust tight).

Second Digit (5) Protection against low pressure jets of water in all directions for a limited amount of time. Water shall have no harmful effects.

To achieve this rating on the C-60+ Series laser, the output optical elements were sealed off for the test and no laser light output was present during the test.

Any user wishing to clean the laser with water jets will have to adopt similar precautions or laser warranty will be voided. Coherent is not responsible for damage to the laser caused by not taking adequate steps to protect the laser optical elements, in particular the output window of the laser. The same applies to external optical elements for the machine the laser is integrated into, or any other structural parts of the laser machine such as control electronics, motors, drives, cables and other accessories.

A copy of the report on the testing carried out to qualify this laser at IP65 level is available on request from Coherent.

4.7 Air Cooling

The C-60+ Series air-cooled lasers incorporate heat sinks cooled by forced air (blown by fans). The six fans draw 3.1 A of current when supplied with the required 48 VDC electrical power. Running the fans at higher voltages will reduce the operating life and is strongly discouraged. The user must provide the correct voltage polarity to the fans in order for the airflow direction and resulting volume to be sufficient to cool the laser adequately.

4.7.1 Air Flow

Open-air flow for the laser system is critical. Therefore, Coherent requires clear access to free air within 60 mm of the cooling fans and fins for the laser system. The air used to cool the C-60+ Series must be clean and free of contaminants. This requirement can be achieved by ensuring that the air in the system or enclosure where the laser is installed is appropriately filtered.

4.7.2 Air Flow Inspection

If air filtering is not possible, or the environment is dusty, frequent inspection of the fans and heat sinks (depending on the severity of the environment where the laser is located), is strongly recommended. These parts need to be cleaned to maintain adequate laser cooling.

4.7.3 Signal Interface

Coherent uses a temperature interlock to ensure that the fans are operating and supplying sufficient air cooling. It is recommended that both Modulation and Control Enable be commanded to the OFF state when the airflow interlock system detects an over-temperature fault. The system also provides a temperature warning that should be used to alert the user to a need for maintenance of the cooling system to return the performance to the normal full cooling capacity. Failure to take action regarding the temperature warning will result in poorer product performance (outside specifications) and lesser product lifetime. These signals are listed in Table 4-4, "Signal Interface Description and Connector Pinout," on page 54 and further discussed in subsections of "Laser Operation" (p. 57) in the operator's manual.

4.8 Liquid Cooling

The C-60+ Series liquid-cooled lasers are cooled by means of liquid coolant. The cooling system, external to the laser head and the RF power module, is the responsibility of and must be supplied by the user. A schematic of the recommended configuration of the cooling system is shown in Figure 4-3.

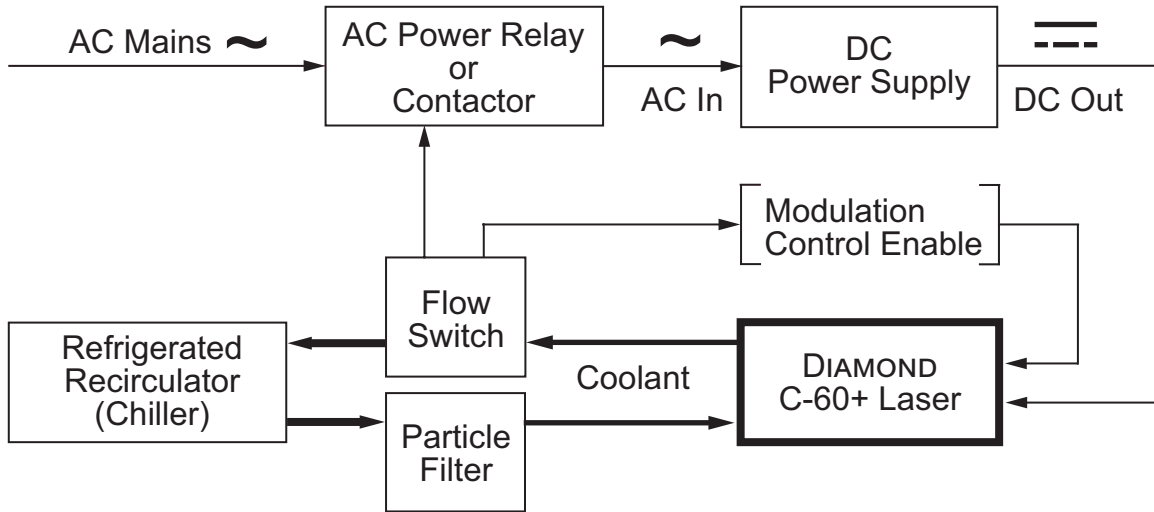

Figure 4-3. Recommended Liquid Cooling System Functional Block Diagram

4.8.1 Cooling System Layout

By connecting the laser head and the RF power module in series, a single interlock will protect the laser system.

Following the flow of coolant from the refrigerated recirculator, the laser head is the first element reached by the coolant after it leaves the recirculator. This assures that the laser head receives the lowest-temperature coolant available.

To prevent inadvertent operation of the laser without adequate coolant, an interlock must be provided so that laser operation is halted in the event that coolant flow is not present. Refer to coolant requirements in Table 3-2 (p. 30).

4.8.2 Coolant Composition

The required coolant composition is a mixture of clean distilled or deionized water containing a low toxicity corrosion inhibitor. THE USE OF CORROSION INHIBITOR IS MANDATORY IN THE C-60+ SERIES LASER! Coherent has tested two different solutions that will prevent corrosion within the laser coolant circuit.

These are described in Table 4-1:

Table 4-1. Recommended Coolant for C-60+ Series Lasers

Product Name	Manufacturers Name and Contact	Heat Transfer Fluid Type	Required Heat Transfer Fluid Content	Freezing Burst Protection	Other Precautions
OptiShield	OptiTemp. Inc. www.optitempt.com US/Canada 231-946-2931	Corrosion Inhibited Water	10% solution in water	Does not reduce the water freezing point	Use may be restricted in geographical locations outside the US
DOWFROST™	Dow Chemical Inc. www.dow.com 989-636-1000	Inhibited Propylene Glycol and Water	30% in water	At 30% mix will provide burst protection to --25°C (13°F)	See Note below

Note on the use of Dowfrost:



Using Dowfrost at 30% in distilled water changes the heat transfer capacity of the water and also its viscosity. This means that the laser will be efficiently cooled as long as the specified flowrate of 1 gpm is maintained.



NOTICE!

Failure to provide adequate cooling to the laser will result in unstable operation and potential failure.

Figure 4-4 shows system components from water circuits treated with inhibitor and a water circuit without inhibitor.



Untreated Water Circuit



Treated Water Circuit

Figure 4-4. Water Circuits - Untreated and Treated

4.8.2.1

Freeze/Burst Protection

The recommended coolant mixture does not provide freeze protection; therefore the coolant temperature must be maintained above the freezing point of water. Since lower temperatures may occur during shipment and storage, the C-60+ Series should never be stored or transported unless the coolant has been completely removed by using a compressed air supply to blow out all coolant passages.



NOTICE!

Never store or ship a C-60+ Series with coolant installed, as the coolant may freeze and cause permanent internal damage. Always remove the coolant prior to storage or shipment by using a compressed air supply to blow out all coolant passages. Plug or cap coolant inlet and outlet fittings after draining to prevent residual coolant leaks during storage or shipment. Damage to the laser during storage or shipment, as a result of failure to remove coolant and plug the inlet and outlet fittings after coolant removal, is specifically excluded from the product warranty.

4.8.3 Alternative Coolant Composition

An alternative coolant composition is a mixture of water and DOWFROST, a low toxicity, corrosion inhibited, propylene glycol based heat transfer fluid available from The Dow Chemical Company. Because this fluid consists of propylene glycol and non-toxic corrosion inhibitors, the legal and regulatory restrictions on its use and disposal are less demanding than is the case for fluids containing ethylene glycol. The required mixture is 25% to 30% DOWFROST by volume, with the balance consisting of water. In addition to DOWFROST, alternative propylene glycol based heat transfer fluids may also be used, as indicated in Table 4-2. In addition, for those applications where the user determines that the higher toxicity of an ethylene glycol based heat transfer fluid is acceptable, the fluids indicated in Table 4-3 may be used.

Table 4-2. Propylene Glycol-Based Heat Transfer Fluids for C-60+ Series Lasers

Product Name	Manufacturer's Name and Telephone Number	Suggested Distributor and Contact Information	Heat Transfer Fluid Type	² Required Heat Transferred Fluid Content in Coolant	Assured Burst Protection
¹ DOW-FROST or DOWCAL N	The Dow Chemical Company U.S./Canada: 1-800-447-4369 Europe: +31 20691 6268 Elsewhere: 1-517-832-1556	U.S.: Hubbard-Hall, 1-203-756-5521 www.hubbard-hall.com or: S/C Industries, Inc. 1-800-675-4785	Inhibited propylene glycol	25 vol% to 30 vol%	- 18°C (0°F)
<p>¹DOWCAL N is a Dow Chemical product functionally equivalent to DOWFROST. DOWCAL N is available primarily in Europe, and DOWFROST is available primarily in the U.S. and Canada. ²The balance of the coolant consists of water with low mineral content.</p>					

Table 4-3. Ethylene Glycol-Based Heat Transfer Fluids for C-60+ Series Lasers

Product Name	Manufacturer's Name and Telephone Number	Suggested Distributor and Contact Information	Heat Transfer Fluid Type	¹ Required Heat Transferred Fluid Content in Coolant	Assured Burst Protection
DOWTHERM SR-1	The Dow Chemical Company U.S./Canada: 1-800-447-4369 Europe: +31 20691 6268 Elsewhere: 1-517-832-1556	U.S.: Hubbard-Hall, 1-203-756-5521 www.hubbard-hall.com	Inhibited ethylene glycol	30 vol% to 35 vol%	- 27°C (-17°F)
¹ The balance of the coolant consists of water with low mineral content.					

Coherent has found that to be safe, distilled water is highly recommended as the dilution water component of the coolant mix. Recommended guidelines on dilution water quality are as follows:

- Chlorides and sulfates in dilution water less than 25 ppm
- Total hardness as calcium carbonate less than 100 ppm

The manufacturers listed in Table 4-2 and Table 4-3 offer prediluted mixtures. The water dilutions indicated in these tables are appropriate only for the undiluted product in each case.

See "Maintenance and Troubleshooting" (p. 71) in the operator's manual for maintenance and replacement requirements for the coolant.



NOTICE!

To prevent damage to the laser, never operate any C-60+ Series liquid-cooled laser using only ordinary water, such as tap water or deionized water, as a coolant. These lasers contain materials which will suffer corrosion damage when exposed to plain water without corrosion inhibitors. Corrosion caused by improper coolant voids the warranty.

It is important to neither use too much, nor too little corrosion inhibited glycol in the coolant mix. Too much glycol will result in poor cooling performance, and possibly overheating of parts of the laser system. Too little glycol will result in reduced protection against corrosion, freezing, and bursting. Glycol fluid levels lower than the recommended amount may also encourage microbial growth, which can result in fouling and blockage of the cooling system.

4.8.4 Freeze/Burst Protection

With the recommended alternative coolant mixes, burst protection is assured down to a temperature of - 18°C (0°F) for the propylene glycol based fluids (Table 4-2) and to - 27°C (- 17°F) for the ethylene glycol based fluids (Table 4-3). Since lower temperatures may occur during shipment and storage, C-60+ Series lasers should never be shipped or stored unless the coolant has been drained. And it is strongly suggested that the coolant within cooling lines of the laser system components be blown out with dry air or Nitrogen.



NOTICE!

To avoid damage, never ship or store any C-60+ Series laser containing coolant if it is possible it will be exposed to temperatures below the freezing point of the coolant during such shipment or storage. Plug or cap coolant inlet and outlet to prevent coolant leaks during shipment or storage.

4.8.5 Re-Circulation and Coolant Flow Interlock Switch

The coolant flow interlock switch should be the last element traversed by the coolant before it returns to the coolant filter in the return line. This assures that the flow switch verifies that coolant is flowing through the laser system. The flow switch must not be placed in any other position. The interlock, which is tripped when the coolant switch indicates no flow or low flow, cuts off AC power to the RF power module to prevent the system from overheating.

4.8.6 Signal Interface

The signal interface in the laser interlock system may be used to turn the laser off when the coolant interlock is breached. With this approach, the laser is commanded to shut down via the signal interface, in the event that the coolant interlock system detects a coolant fault. Coherent recommends that both Modulation and Control Enable be commanded to the OFF state when the coolant interlock system detects a coolant fault. These signals are listed in Table 4-4, "Signal Interface Description and Connector Pinout," on page 54 and described in subsections of "Laser Operation" (p. 57) in the operator's manual.

4.8.7 Thermal Shutdown Circuit

The C-60+ Series lasers have a thermal protection circuit that protects the system at case temperatures over 73°C. Coherent recommends, however, that the OEM install sensors that detect coolant flow and shuts the laser down in the event of loss of coolant.

The system also provides a high temperature warning. This warning is used to alert the user to the need of maintenance in order to return the cooling system performance back to normal, full cooling capacity. Failure to take action regarding the temperature warning will result in poorer product performance (outside specifications) and lesser product life time.

4.8.8 DC Power Relay

The recommended DC power relay used to cut DC power to the laser off, in the event of cooling system failure, can also be used as part of the laser safety interlock system. Similarly, if the signal interface is used to shut down the laser when there is a cooling system fault, the signal interface can be used to shut down the laser in the event that there is a breach of a safety interlock. The design of the interlock controls must be in compliance with applicable safety standards, including those described in “Laser Safety” (p. 9).

4.8.9 Condensation of Water Vapor

If the coolant temperature is below the dew point of the ambient air, water will condense out of the air onto the outside of the laser head. It will also form onto the outside surface and internal surfaces of the RF power module. Condensation can damage the output optical element of the laser head when the laser is turned on, and could damage internal components of the RF power module if power is applied while condensate is present.



NOTICE!

To avoid damage to the laser head and RF power module, never allow the coolant temperature to fall below the dew point of the ambient air. Turn the coolant flow off if the laser will be off or stored for an extended period of time in humid conditions.

If necessary, the laser system can operate with coolant temperatures slightly below the dew point of the ambient air. This requires special procedures to be followed, such as shutting off the coolant flow at all times when the laser is not producing laser output. Contact Coherent Customer Service for more information about this option before attempting to operate the system in ambient air below the dew point.



NOTICE!

To avoid possible damage to the laser head, never attempt to change the coolant fittings at the locations where the coolant enters the laser head. If the fittings must be changed for any reason, return the laser head to Coherent to be serviced by Coherent technicians.

4.8.10

Coolant Fittings on Laser System

The C-60+ Series liquid-cooled lasers have 8 mm O.D. tubing for the connection interface. The user must supply an appropriate compression fitting to make the connection with the rest of the user's system.

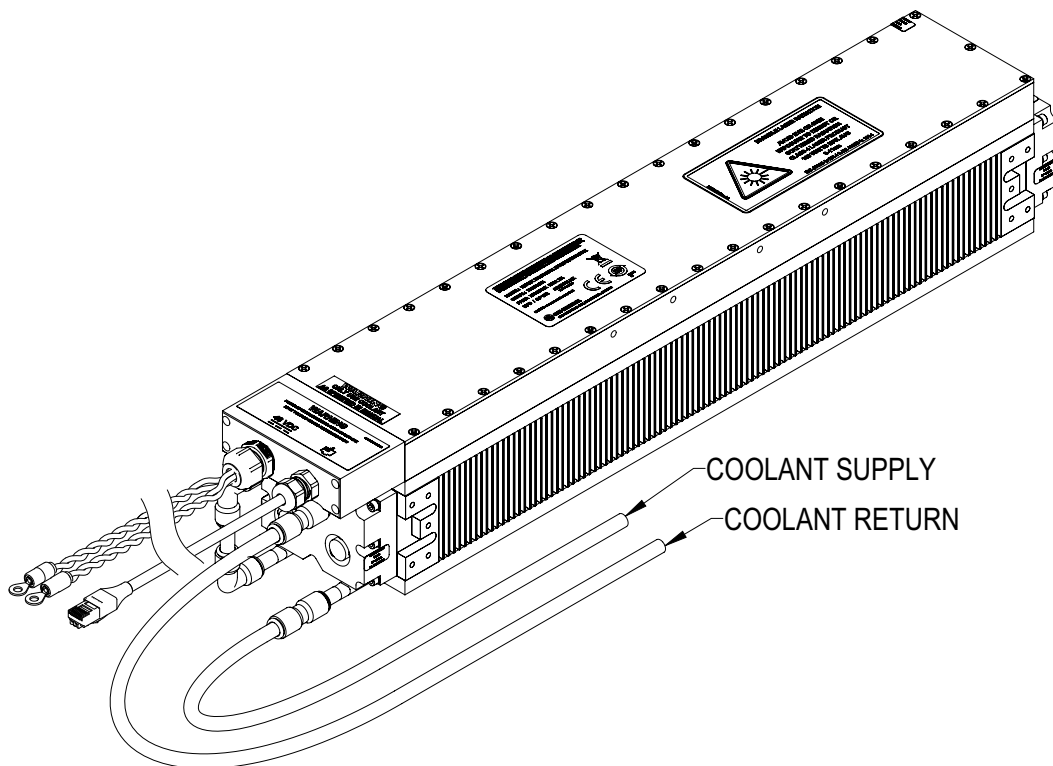

Figure 4-5. C-60+ Series Liquid Cooling Connections

4.8.11 Cooling Capacity

The cooling system must have sufficient capacity to maintain the coolant temperature at the outlet of the refrigerated recirculator within the range given in Table 3-2 (p. 30). With the laser operating at its maximum output power, the cooling system must dissipate up to 1200 W. See “Maintenance and Troubleshooting” (p. 71) in the operator’s manual for maintenance and replacement requirements for the coolant.

4.8.12 Coolant Filtering

Coherent recommends that the user incorporate coolant filtering in the coolant return line to avoid the accumulation of debris in the cooling system, as shown in Figure 4-3. The filter should trap particles larger than 30 μm to 50 μm in size, unless specified otherwise by the manufacturer of the refrigerated recirculator.

4.8.13 Coolant Flow Rate and Pressure

Requirements on coolant flow rate are listed in Table 3-2 (p. 30). To prevent damage to the laser head or the RF power module, the gauge pressure of the coolant at the laser head and at the RF power module must not exceed 100 psig (i.e. the gauge pressure – the difference between the absolute pressure of the coolant and the absolute pressure of the ambient air – must not exceed $7\text{kg}/\text{cm}^2$, or 700 kPa). Note that the gauge pressure at the laser system includes the effect of the gravitational pressure change if the refrigerated recirculator is mounted much higher than the laser system.



NOTICE!

Exceeding the maximum allowed gauge pressure in the laser head or RF power module, even for a short period of time, may cause irreversible damage and result in permanent coolant leaks.

Depending on the customer’s overall cooling system design, portions of the cooling system other than the laser head and the RF power module, may limit the maximum-allowed gauge pressure of the coolant to a lower pressure than the value noted above for the laser head and the RF power module.

4.8.14 Pressure Drop

The pressure drop from the coolant outlet to the coolant inlet of the refrigerated recirculator will depend on many factors, including:

- Flow rate
- Temperature
- Length and inside diameter of coolant hoses and connections
- Coolant composition

To achieve the minimum flow rates given in Table 3-2 (p. 30), provide a pressure differential of at least 206 kPa (30 psi) between the coolant inlet and coolant outlet of the laser. In addition, there is some pressure drop in the cooling lines, which depends primarily on the diameter and length of these lines.

4.9 Electrical Power Connection

The C-60+ Series lasers require 48 VDC input DC power. This power is carried from the power source to the system through the 48 VDC power wires. The maximum continuous current is 20 A.



NOTICE!

To avoid damage to the laser head, connect leads to the user-supplied power source last, after other connections are made.

The negative (return) side of the DC input connection to the C-60+ Series RF power module is connected internally to the chassis. The user must assure that the system into which the C-60+ Series is built protects against the possibility that the C-60+ Series chassis could be at a hazardous voltage and that personnel could be exposed to these voltages.



DANGER!

To avoid potentially fatal electrical shock hazards from electrical equipment, follow all applicable electrical codes such as (in the U.S.) the National Electrical Code.

Coherent strongly recommends that the user review the precautions described in “Laser Safety” (p. 9) regarding electrical safety before using the C-60+ Series lasers. It is the user’s responsibility to provide circuit breakers and/or fusing of the AC power source in accordance with all applicable laws and regulations.

4.9.1 DC Power Supply Requirements

The following are the requirements for the customer-supplied DC power supplies.

DC Voltage:	48 VDC measured at the terminals.
Peak Current:	35 A for a minimum of 1 ms with a maximum voltage drop of 1.5 V
Regulation:	< ± 2%
Regulation Sensing:	Remote at load
Ripple and Noise:	< 1% p-p (20 MHz BW limit)
Overload and Short Circuit Protect:	Automatic Recovery

4.9.1.1 DC Power Supply Cabling Requirements



Coherent recommends the use of remote voltage sense/regulation at the C-60+ Series. This requires a 4-wire cable (2 supply currents and 2 voltage senses).

The following requirement minimizes the voltage loss from supply to the C-60+ Series:

Wire length (in Meters)	AWG
0-2	2 x 17 or 14
2-3	2 x 15 or 12
3-5	2 x 13 or 10

4.10 Control Signal Connection

Electrical control of the C-60+ Series lasers is achieved via an RJ-45 connector built into the system. The signals carried on each of the pins are indicated in Table 4-4. Details about controlling the laser through the signal interface are discussed in “Laser Operation” (p. 57) in the operator’s manual.

Table 4-4. Signal Interface Description and Connector Pinout

Pin No.	Signal Description
1	Modulation TTL logic input; 1=RF ON, 0=RF OFF; 1 kΩ impedance This input turns on the laser. See also Pin 7, Control Enable, below
2	+ 15 VDC ± 0.5 VDC, 0.25 Amps Max output for customer use
3	LASER OK TTL logic output; 1=LASER OK, 0=LASER Fault; I _{OH} = -0.4 mA, I _{OL} = 8 mA Output is asserted when no faults (VSWR, Temp. or Volt.) are detected
4	Temperature OK TTL logic output; 1=Temp OK, 0=Temp Fault; I _{OH} = -0.4 mA, I _{OL} = 8 mA Output is asserted when temperature is below the 60°C warning level The temperature fault will occur at a case temperature of approximately 73°C
5	Voltage OK TTL logic output; 1=Voltage OK, 0=Voltage Fault; I _{OH} = -0.4 mA, I _{OL} = 8 mA Output is asserted when DC supply voltage (V _{DD}) is between 43 VDC < V _{DD} < 55VDC
6	Temperature Monitor TTL logic output. This pin puts out a pulse width modulated signal that represents the internal laser temperature in degrees Celsius. The positive duty cycle of the signal directly represents the temperature. For example, a duty cycle of 35% represents 35°C. A duty cycle of 0% represents a temperature of 0°C or below, and a duty cycle of 100% represents a temperature of 100° C or above.
7	Control Enable TTL logic input; 1=Laser Control Enabled, 0=Laser Control Disabled This input must be asserted before Modulation can be used to turn on laser
8	Customer Logic Ground for all interface signals
Notes: 1) Connector used is RJ-45 type. 2) These specifications are subject to change.	



NOTICE!

Coherent highly recommends use of shielded interface cables. The interface cable shield must connect to the chassis ground of the controller. In addition to proper shielding, this shield provides a secondary connection for the signal ground (Pin 8).

A floating ground connection (use of un-shielded interface cable or no return path between the host control electronics and the laser) can present an unsafe condition and result in unstable or unexpected operation of the laser. This condition can arise when the control signal ground connection (Pin 8) is lost and the Control Enable (Pin 7) and Modulation (Pin 1) remain high. Therefore, Coherent strongly recommends that a second safety ground be provided either via a shielded control cable or common potential chassis mounting between the laser head and the control electronics. Inadequate or nonexistent grounding between the laser and the external control system can result in loss of control of the laser and damage to the laser electronics or the external control electronics.

4.11 Beam Propagation

The true waveguide structure of the C-60+ Series delivers a 1.8 mm $1/e^2$ diameter beam with a 7.5 mrad $1/e^2$ full angle divergence. The typical beam diameter as a function of distance from the laser is shown in Figure 4-6.

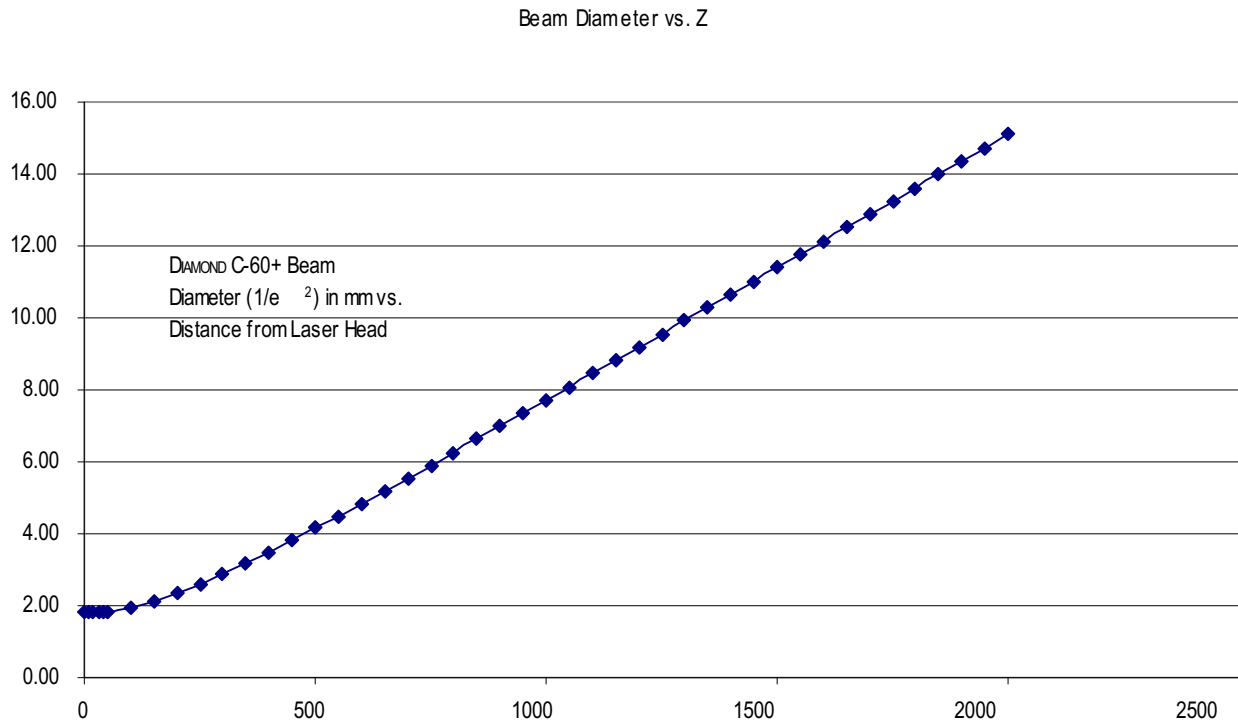

Figure 4-6. Beam Diameter vs. Distance from Laser Head



DIAMOND C-60+ Series OEM Lasers Preinstallation Manual
©Coherent Inc., 5/2022 (RoHS), printed in the USA and Thailand
Part No. 1415778 Rev. AB

