

版本号	<p style="text-align: center;"> <u>RFL-P200/ RFL-P300</u> <u>200W/300W 脉冲光纤激光器 英文说明书</u> <u>RFL-P200/ RFL-P300 • JS02</u> 部 门 <u>脉冲激光器技术研究部</u> 编 写 <u>王致远 20210219</u> 校 对 <u>刘 红 20210219</u> 审 核 <u>李 科 20210220</u> 标 审 <u>李其军 20210220</u> 批 准 <u>黄 保 20210224</u> </p>	密级	内部		
A0		阶段 标记			D
会签					
朱超					
汪昶					
高辉					
旧底图登记号					
/					
底图登记号					
/					

武汉锐科光纤激光技术股份有限公司

RFL-P200 / RFL-P300

Pulsed Fiber Laser

User Guide

TABLE OF CONTENTS

1 Safety Information	1
1.1 Security Warning.....	1
1.2 Laser Safety Grade	1
1.3 Safety Identification	2
1.4 Optical Safety	3
1.5 Electrical Safety	3
1.6 Other Safety Rules	3
2 Product Description	4
2.1 Features	4
2.2 Package Parts.....	4
2.3 Unpacking and Inspection	4
2.4 Operation Environment	5
2.5 Attentions	6
2.6 Specifications	6
3 Installation	8
3.1 Dimensions.....	8
3.2 Cooling Requirements.....	10
4 Using the Product.....	12
4.1 Front Panel	12
4.2 Rear Panel	13
4.3 Power Connection	14
4.4 Interface Definitions.....	15
4.4.1 SERVICE	15
4.4.2 Control Interface	16
4.4.3 RS-232 Serial Port.....	19
4.5 Application Steps of Laser Device.....	20
4.5.1 Pre-inspection.....	20
4.5.2 Operational Steps	20
4.5.3 Attention in the process of operation	21
5 Common Alarms and solutions.....	21
6 Warranty, Return and Maintenance.....	22
6.1 General Warranty	22
6.2 Limitations of Warranty	23



受控

6.3 Service and Repair 23

武汉锐科



1 Safety Information

Thank you for choosing Raycus fiber laser. This User Guide provides important safety, operation, warranty and other information. Please read it carefully before use this product. In order to ensure safe operation and optimal performance of the product, please follow the warnings, cautions, operating procedures and other instructions accordingly.

1.1 Security Warning

	WARNING: Describes a hazard that lead to a personal injury or death.
---	---

	CAUTION: Describes a hazard that lead to a minor personal injury or product damage.
--	--

1.2 Laser Safety Grade

According to the European Community standards EN 60825-1, clause 9, this series of lasers are classified as a high power Class 4. This product emits invisible laser radiation at wavelength of 1064 nm, and the maximum power is 300W. Direct or indirect exposure of high power of laser radiation may cause damage to the eyes or skin. Despite the radiation being invisible, the beam may cause irreversible damage to the retina and cornea. Appropriate and approved laser goggles must be worn all the time during the laser device is operating.

	WARNING: Users must use appropriate laser goggles when operating this device. The laser goggles is selected according to the range of wavelength emitted from this product. Users must ensure that the protect range of laser goggles over the entire range of laser wavelengths. Please do not directly view the laser output head when laser emitting.
---	---



1.3 Safety Identification

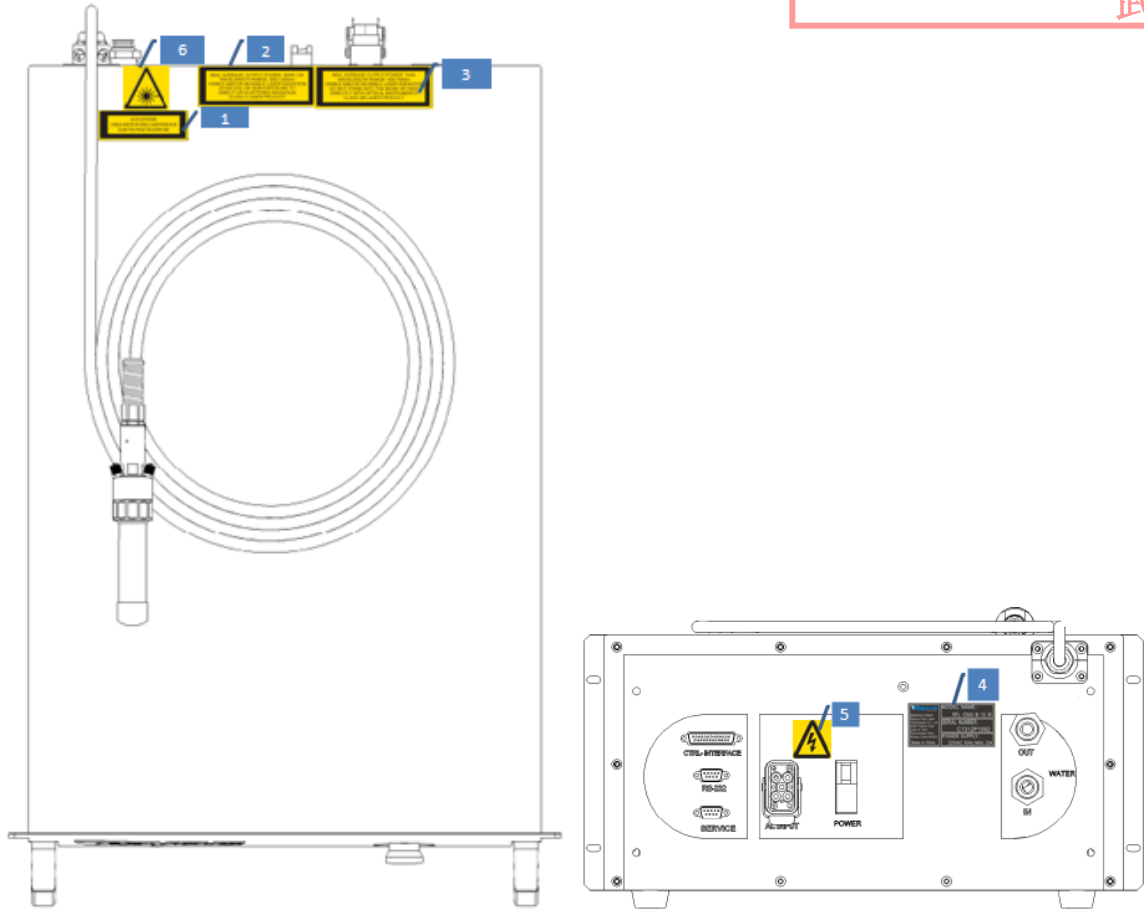

Figure 1 : Safety identification position

Table 1: Safety identification

<p>AVOID EXPOSURE—VISIBLE AND/OR INVISIBLE LASER RADIATION IS EMITTED FROM THIS APERTURE</p> <p>Per IEC 60825-1:2014</p> <p>English Label</p> <p>避免受到从本窗口射出的可见及不可见激光辐射的照射</p> <p>GB 7247.1-2012/IEC 60825-1:2007</p> <p>Chinese Label</p>	<p>MAX.AVERAGE OUTPUT POWER:200W MAX. PEAK OUTPUT POWER:150kW WAVELENGTH RANGE:1000-1200nm PULSE DURATION:70-130ns PULSE REPETITION RATE:10-50kHz DANGER—VISIBLE AND/OR INVISIBLE LASER RADIATION AVOID EYE OR SKIN EXPOSURE TO DIRECT OR SCATTERED RADIATION CLASS 4 LASER PRODUCT Per IEC 60825-1:2014</p> <p>English Label (200W)</p> <p>最大平均输出功率:200W 最大峰值输出功率:150kW 波长范围:1000-1200nm 脉冲宽度:70-130ns 脉冲重复频率:10-50kHz 可见及不可见激光辐射 避免眼或皮肤受到直射或散射辐射的照射 4类激光产品 GB 7247.1-2012/IEC 60825-1:2007</p> <p>Chinese Label (200W)</p>	<p>MAX.AVERAGE OUTPUT POWER:1mW WAVELENGTH RANGE:600-700nm VISIBLE LASER RADIATION DO NOT STARE INTO BEAM OR EXPOSE USERS OF TELESCOPIC OPTICS CLASS 2M LASER PRODUCT</p> <p>Per IEC 60825-1:2014</p> <p>English Label</p> <p>最大平均输出功率:1mW 波长范围:600-700nm 可见激光辐射 勿直视或通过光学仪器直接观看光束 2M类激光产品 GB 7247.1-2012/IEC 60825-1:2007</p> <p>Chinese Label</p>
<p>1: Laser Emit Head</p>	<p>2: Type 4 Laser Product</p>	<p>3: Class 2M Laser Product Label-2mW Red Laser</p>
<p>4: ID Label</p>	<p>5: Electrical Hazard</p>	<p>6: Laser Radiation Hazard</p>



1.4 Optical Safety

Any dust on the end of the collimator assembly can burn the lens and damage the laser device.

	CAUTION: DO NOT emit when the protective cap is not removed, otherwise the lens or crystal will be damaged.
---	--

1.5 Electrical Safety

- a) Ensure the product is grounded through the PE line of the AC power cord. The grounding must be firm and reliable.

	WARNING: Any interruption from the protective earth will electrify the enclosure, which may result in personal injury.
---	---

- b) Ensure that the AC voltage is supplied normally.

	CAUTION: Wrong wiring mode or power supply voltage will cause an unrecoverable damage to the laser device.
---	---

1.6 Other Safety Rules

- Do not directly view the laser output head when laser emitting. Avoid using the laser in a dark environment.
- Do not use fiber lasers in dark environments.
- If this device is used in a manner not specified in this document, the protection provided by the device may be impaired and the warranty will be voided.
- There are no user serviceable parts, equipment or assemblies inside the product. All service and maintenance shall be performed by Raycus. In order to prevent electric shock, please do not break the seal or uncover the shield. Failure to comply with this instruction will void the warranty.

2 Product Description

2.1 Features

Raycus pulse fiber laser is designed for industrial and scientific research applications with high pump conversion efficiency, low power consumption and excellent beam quality. It is compact and ready to use. It can be used as a stand-alone unit or easily inserted into user's apparatus.

Main Features:

- Uniform distribution of stop energy
- Fiber output
- High reliability, long-life
- Maintenance free operation
- High photoelectric efficiency

Applications:

- Laser cleaning
- Scientific research

2.2 Package Parts

Please refer to package accessories are in the packing box.

2.3 Unpacking and Inspection

Raycus fiber laser is delivered in a package, which is designed to offer the maximal safety. Upon the delivery, please inspect all packaging for evidence of mishandling or damage. If you find any evidence of mishandling, please keep the damaged material and contact the shipping agent and Raycus immediately.

Please double check if each listed contents is inside the package; and contact Raycus as soon as possible if there is any issue.

Take extra care when removing the unit from the package to make the fiber optic cable stay away from collision and vibration. Please do NOT distort, bend or

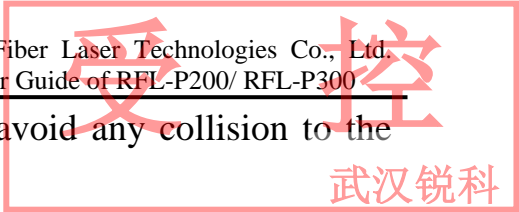

pull the output cable when unpacking the device; and avoid any collision to the head of laser output.

	<p>CAUTION: The fiber optic cable and output head are precise optic instrument, ANY vibration or impact to the output head, and twist or excessive bend to the cable will damage the instrument.</p>
---	---

2.4 Operation Environment

The operation conditions are listed as the following table:

Table 2: The Operation Environment Conditions for the Laser

Power Supply		AC 220V ±10%、50/60Hz
Max. Power Consumption (W)	RFL-P200	≥1200W
	RFL-P300	≥1800W
Installation Environment		Flat and no vibration
Ambient Temperature		10°C ~ 40°C
Relative Humidity		≤70%
Weight(kg)		50kg

- a) Make sure the product is properly grounded before use.
- b) The laser output head is connected with fiber optic cable. Please inspect the output head carefully for dust or other contaminations. Use appropriate lens paper to clean it if necessary.
- c) Failure to follow the instructions when operating the laser may cause malfunction and damage.
- d) It is not allowed to install the output head when the laser is in operation.
- e) Do not look into the output head directly. Wear appropriate protective eye glasses all the time when operating the laser.

It is recommended to install the product in an environment with air conditioning.

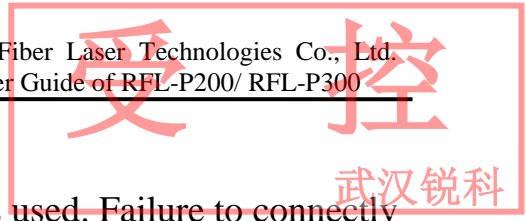

2.5 Attentions

- a) Make sure that the correct voltage of 220V AC is used. Failure to correctly connect power supply will damage the device.
- b) The output laser is collimated by the collimating lens, it is important to keep the collimating lens clean, otherwise it will damage the device.
- c) Please cap the output head when it is not in use. Do not touch the output lens at any time. Use appropriate lens paper to clean it if necessary.
- d) Safety keep the cap when using the laser. To avoid dust, make sure the opening direction of the cap is put down.
- e) Failure to follow the instructions may cause laser power loss, such loss is not covered by warranty.

2.6 Specifications

Table 3 Product Specifications

Items	Test Condition	Value		Unit
Optical Characteristics				
Product Type		RFL-P200	RFL-P300	
Operation Mode		Pulse		/
Polarization State		Random		/
Output Power	RR=10kHz Pmax	$100 \leq P \leq 110$	/	W
	RR=20kHz Pmax	$200 \leq P \leq 210$	$250 \leq P \leq 260$	W
	RR=30kHz Pmax	$200 \leq P \leq 210$	$300 \leq P \leq 310$	W
	RR=50kHz Pmax	$200 \leq P \leq 210$	$300 \leq P \leq 310$	W
Output Power Tunability	/	10-100		%
Emission Wavelength	RR=50kHz P=Pmax	1064 ±5		nm
Spectral Width	RR=50kHz P=Pmax	≤10		nm
Output Power Unstability	5Hrs later/RR=50kHz P=Pmax	≤5		%
Pulse length	RR=10kHz P=Pmax	90-110	/	ns

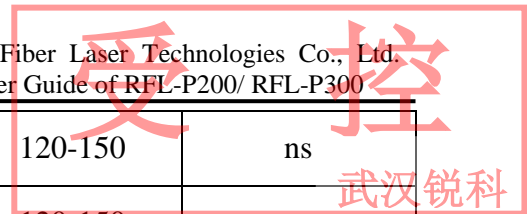

	RR=20kHz P=Pmax	90-120	120-150	ns
	RR=30kHz P=Pmax	90-120	120-150	ns
	RR=50kHz P=Pmax	90-130	120-160	ns
Pulse turn-off time	RR=50kHz P=100%~ 10%Pmax	<100		us
Repetition frequency	/	10-50	20-50	kHz
Red Guide Laser Power	/	0.1~1		mW
Optical Output Characteristics of QCS head				
Beam Spot Diameter	RR=50kHz/P=Pmax x	3-5		mm
Beam Spot shape*	Flat-topped Beams			/
Delivery Cable Length*	QCS	5		m
Electrical Characteristics				
Power Supply	AC 220V±10%、50/60Hz			V
Max. Power Consumption	RR=50kHz P=100%~ 10%Pmax	1000	1800	W
Control Mode	DB25			/
Other Characteristics				
Dimensions(W×H×D)	485×237×765			mm
Weight	50			kg
Operating Ambient Temperature	10~40			℃
Humidity	≤70			%
Storage Temperature	-20~60			℃
Cooling Method	Water Cooling			/
*means customization				



3 Installation

3.1 Dimensions

Figure 2 shows dimensions of the product.

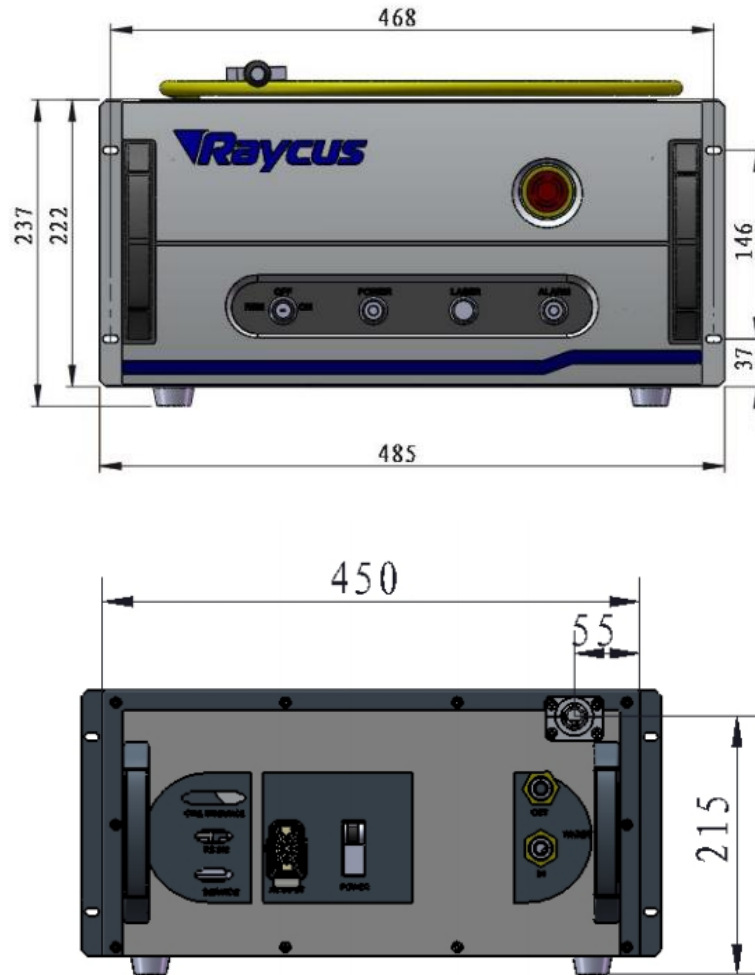

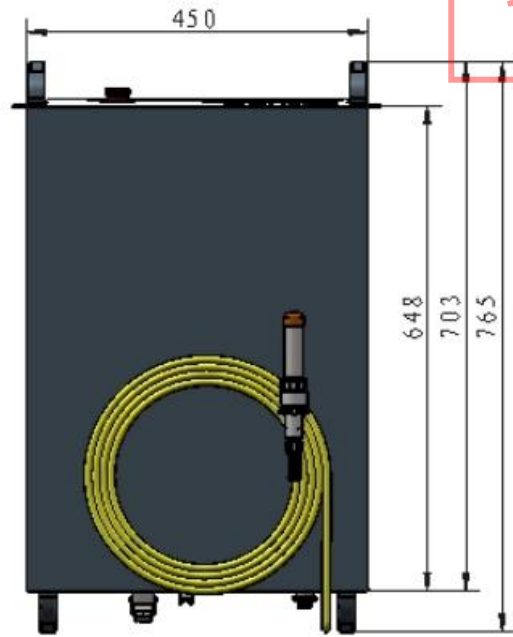
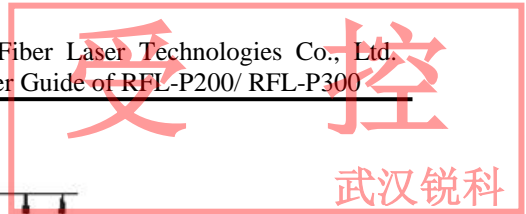

Figure 2: Dimensions of 200W Product (unit:mm)

The output head is QCS, the following figure 3 show the details of the QCS output head.

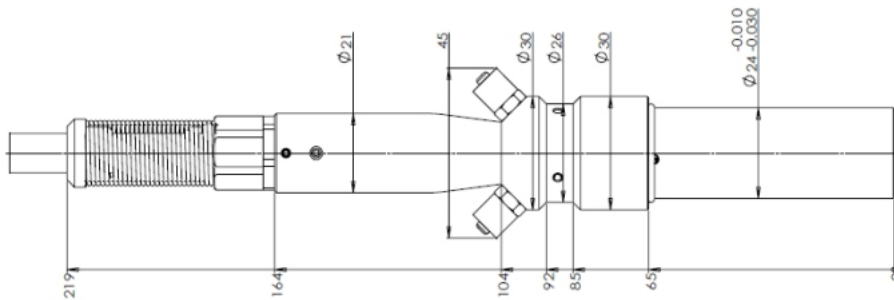

Figure 3 QCS Output head (unit: mm)

	<p>CAUTION:</p> <ul style="list-style-type: none"> a) Keep the protective cap properly, prevent it from contamination; Or the aperture will be contaminated when capped. b) Make sure the aperture and the cavity of the processing head is clean.
--	---



3.2 Cooling Requirements

Table 4 Cooling Requirements

Parameter	Unit	Value
Cooling Capability	W	≥ 1000
Minimum Flow	L/min	4
Maximum Pressure	Bar	8
Water-cooling pipe connector	mm	Pagoda-Type pipe connector, outside diameter 10mm

Temperature setting of cooling water: $25 \pm 0.5^\circ\text{C}$

Requirements on Cooling Water:

- Purified water should be used.
- In order to prevent the growth of mould that may lead to blockage, adding alcohol solution to about 10% of the total volume is recommended.
- If ambient temperature is between -10°C and 0°C , we recommend to use 30% alcohol (volume ratio), and replace it every 2 months.
- If ambient temperature is below -10°C , the chiller with both heating and cooling functions must be used, and keep it in full-time operation.

Other requirements:

- Before start the device, ensure that the flow and return connections are correct connected, and confirm that there is no leakage in all the water circuits. Any abnormal condition in the water circuits may cause a failure to the operation of the laser.
- If the device is not use in a long time, water must be emptied from the device, and then both the inlet and outlet must be blocked with the caps. Failure to do so may cause damage to the device.
- Please use compressed gas below 0.5MPa when emptying water from the device. Failure to do so may cause permanent equipment damage to cooling system.



CAUTION: Please set the water temperature according to the requirements above. Setting the temperature too high may cause an abnormal performance; and liquid water may be condensed on the laser module or the output head if a too low temperature is set, which may cause serious damage to the device.





CAUTION: The cooling system should be turned on first. Check any water leakage and make sure that the water temperature reaches the set point before start the laser. ($25 \pm 0.5^{\circ}\text{C}$)

3.3 Installation rule

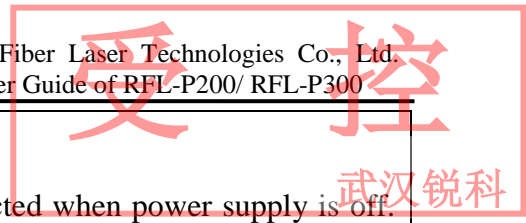
- a) Place the product in an appropriate position, immobilize it if necessary.
- b) Check if the power supply has the correct voltage (220V AC \pm 10%, 50/60Hz), and the earth line is connected, make sure it is firm and reliable.
- c) Connect the power cable and control cable to the product when power supply is OFF.
- d) Clamp the water pipes on top of pipe connector, run the chiller to check if there is any leakage in the water circulation.
- e) Check the output head and clean it before installation. This procedure must be performed by Raycus personnel or person authorized by Raycus.
- f) Prevent the delivery cable from treading, pinching or excessive bending during installation.
- g) Make sure the environment is clean, or the output head may be contaminated. It is prohibited to use fan during installation, which will cause dust in the air.
- h) The minimum bending diameter of the transmission cable of the laser shall not be less than 20cm in the non-working state (such as transport and storage). The minimum bending diameter should not be less than 30cm when the laser is work.



	<p>CAUTION: All the cables can only be connected when power supply is off. Hot plug may damage the device.</p>
---	---

	<p>CAUTION:</p> <ul style="list-style-type: none"> a) Ensure that there are no fiber bends in radius less than 30cm when the product is installed. Avoid excessive twisting and tight bends during the robotic arm movements. b) Tight bends will damage the laser delivery system.
---	--

	<p>CAUTION:</p> <ul style="list-style-type: none"> c) Keep the protective cap properly, prevent it from contamination; Or the aperture will be contaminated when capped. d) Make sure the aperture and the cavity of the processing head is clean.
---	---

4 Using the Product

4.1 Front Panel

Figure 4 shows the front panel.

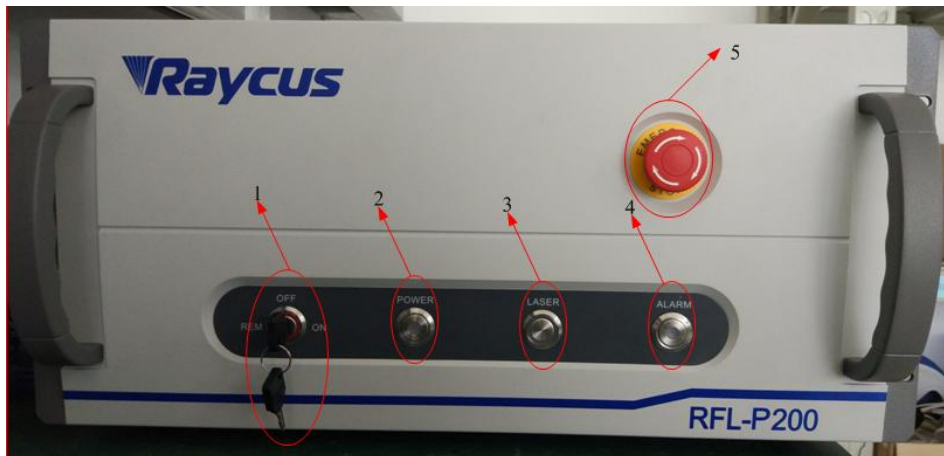
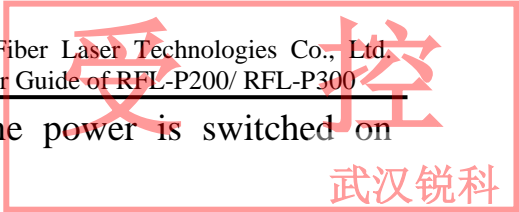

Figure 4 Front Panel View

1. **REM/OFF/ON:** Key switch, the power switch of the laser. Insert the key and then turn the key clockwise to the 'ON' to active the laser.



2. **POWER:**Power Indicator, indicates that the power is switched on when the green LED illumines.
3. **LASER:** Laser emission button, it's a button with an red LED indicator. In RS-232 mode and AD mode, when this button is pressed down, the product is ready to emit laser, and the LED illumines. Press again will release the button, and disable the laser emission.
4. **ALARM:** Alarm indicator, indicates a fault condition when the yellow LED illumines.
5. **EMERGENCY STOP:** Press it down to stop the laser immediately. Turn it clockwise to release, but the laser cannot start before it's powered on with key switch for a second time.

4.2 Rear Panel

Figure 5 shows the rear panel:

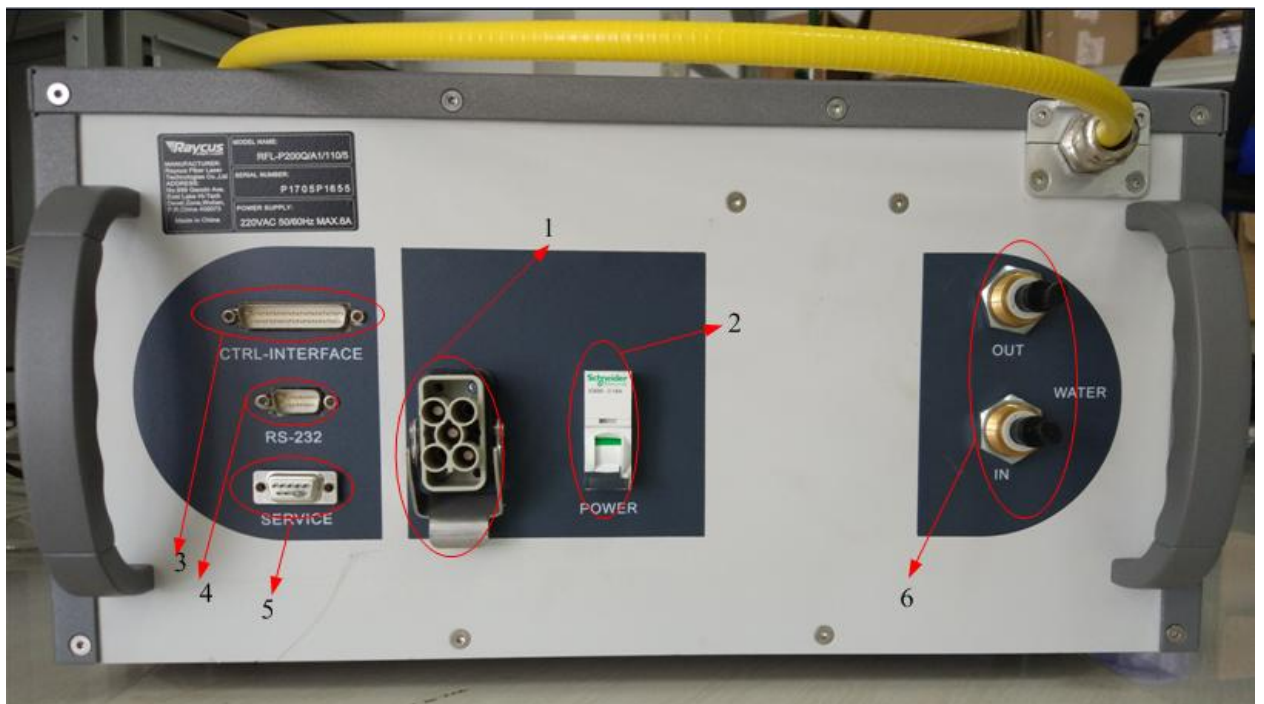
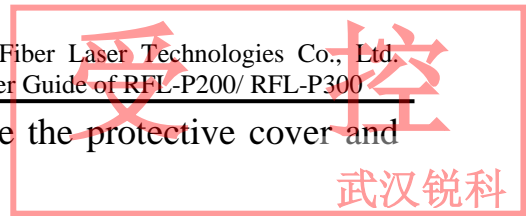

Figure 5: Rear Panel

1. **INPUT:** The socket for supply input that can be only mated with the plug on the power cord we provided.The socket is provided with a



protective cover and a lock catch. Please use the protective cover and lock catch when not use the laser device.

2. **POWER:** Air switch. Controlling the on-off of AC.
3. **INTERFACE:** Control interface. This interface provides all control signals, including RS232 communication, laser switch control, laser remote control mode selection, analog control, modulation signal, Interlock interface. Please reference table 4 for specific definition of control line. The socket is provided with a protective cover and a lock catch. Please use the protective cover and lock catch when not use the laser device.
4. **RS-232:** RS-232 interface. Provides remote control and fault information storage for lasers.
5. **SERVICE:** Provide some external functions for customers. See 4.4.1 Interface Specification for details.
6. **WATER:** The pagoda type pipe connector. The intake and outlet are used for inflow and reflux cooling water.

4.3 Power Connection

	<p>CAUTION:</p> <ol style="list-style-type: none">a) Before connect the product to AC power, you must check up that the AC supply you will apply is in accordance with the specifications provided in Table 1.b) Failure to correctly connect the cable could damage the device. Please check whether the power cable and the control cable is correctly connected before usage.
---	--

A power cord is provided in the package, as in Figure 6



Figure 6 : The Power Cord of the Laser

One end of the power cord is a plug; insert it into the socket ‘AC INPUT’ on the rear panel when using the laser. Notice that the plug is wrong-side preventing. After insert it, lock it with the lever.

□ The other end of the power cord is stripped off labeled L, N and PE, respectively. You should connect the wires to the 220V AC power supply according to the labels:

- L–Fire Line
- N-Null Line
- PE-Ground Wire

4.4 Interface Definitions

4.4.1 SERVICE

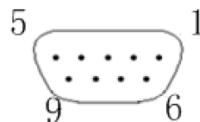

Figure 7: SERVICE Definitions

The pin definitions are shown in Table 5:

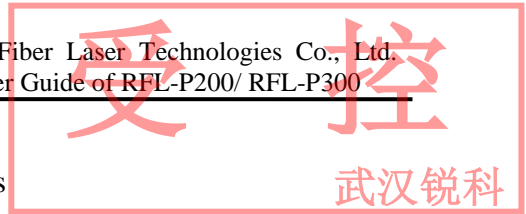

Table 5: SERVICE Definitions

Unit	Definition	Comments
1	Remote key switch	Equivalent to front panel KEY SWITCH.
2		
6	INTERLOCKA	Six and seven legs need to be short-jointed before the laser is emitted.
7	INTERLOCKB	
8	Remote Power ON	Equivalent to front panel LASER
9		

Other pins are idle.

SERVICE interface is a DB9 header. If the pins 6 and 7 are disconnected, the device will immediately interrupt the light, and the Yellow fault alarm lamp will be lit. Six and seven legs need to be short-jointed before the laser is emitted.

	<p>Interlock interface must not access active signal, otherwise it will cause interface damage and laser failure.</p>
--	--

4.4.2 Control Interface

Figure 8 shows a schematic diagram of the DB25 control interface.:

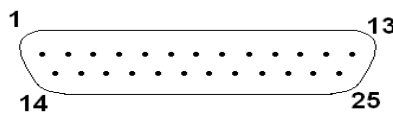

Figure 8: DB25 control interface.

The DB25 behind the power module is the interface between the control system (such as marking machine) and the laser system. Be sure to connect reliably before working. The pins are defined as follows

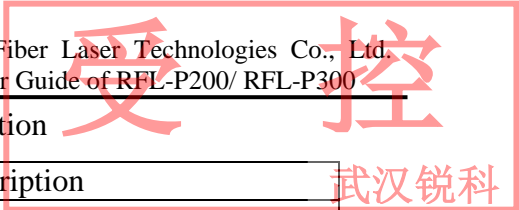

Table 6: DB25 Control Interface Definition

PIN	Function	Description
1-8 (D0-D7)	Power Settings	Data parallel transmission 8bit, D0 is the lowest level, D7 is the highest level; Range: 0-255 (Hexadecimal system: 0X00-0XFF) ; 0: Minimum power output; 255: Maximum output power
10,13-15,24,25	GND	Digital Grounding Aignal (Digital)
11,12,16,21	Laser alarms status	See alarm codes in the table 7
17	VCC	+5VDC power supply input for independent operation of the guide laser and PCB
18	Pre-output optical signal	MO、PA Pre-output optical signal, High level turn on, low level turn off
19	Output optical signal	High level turn on, low level turn off
20	Sync	Pulse Repetition Rate (Synchronization) input, square wave.10KHz-50KHz
22	Guide Laser signal	High level turn on, low level turn off
23	Safety control signal	Lighting is allowed at high level and prohibited at low level. (Customer Access Safety Door)

a) The pump current of diode laser and the laser output power are controlled by setting the value of PIN1-PIN8 (TTL level). PIN1-PIN8 can be set from 0~255, corresponding to the laser output power from 0~100% (the actual laser power may not be strictly linear with the setting value). The relationship between PIN value and output power is shown in Table7:

Table 7:Definition of power control PIN value

	Setting 1	Setting 2	Setting 3	Setting 4
PIN 1	0	0	0	0
PIN 2	0	0	0	0
PIN 3	0	0	0	0
PIN 4	0	0	0	0
PIN 5	0	0	0	1
PIN 6	0	0	1	1
PIN 7	0	1	1	1
PIN 8	1	1	1	1
Current	~50 %	~75 %	~87.5 %	~93.75 %

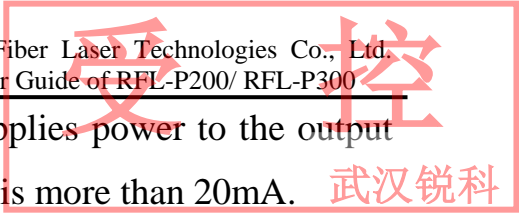

- b) Pin 17 is an external 5V power input, which supplies power to the output optocoupler of the alarm signal; the input current is more than 20mA.
- c) The external input signals (Pin 1-8, 18, 19, 20, 22) of the laser are all connected with optocouplers inside the system to ensure that the input level is high in the range of 3.3V-5V and low in the range of 1.7V. Pin input current is greater than 7 mA.
- d) Warning Signal Definition:

Table 8 Warning Signal Definition

12PIN	11PIN	16PIN	21PIN	Alarm item
Spare	Low	Low	Low	Temperature alarm
Spare	High	Low	Low	Power failure
Spare	Low	Low	High	Normal
Spare	High	Low	High	Device not ready
Spare	Low	High	Low	Laser High Reflection Warning
Spare	Low	High	High	system failure
Spare	High	High	Low	Spare
Spare	High	High	High	Spare

- e) Laser warning output signals (PIN 16,21) are all connected with optocouplers, and 17 pins 5V power supply is needed to get an effective signal.
- f) Note: The pre-output light signal (needle 18) must be at least 5 ms earlier than the output light signal (needle 19), otherwise the laser will be damaged easily.



Schematic diagram of input signal interface circuit:

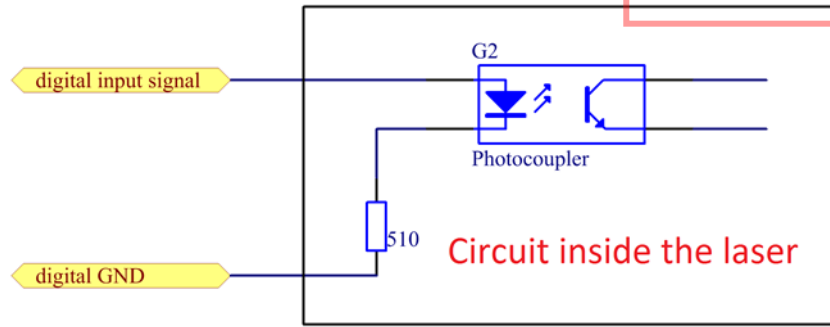

Figure 9: Schematic diagram of input signal interface circuit

Signal input needs to be able to provide at least 7 mA of current. The schematic diagram of the output signal interface circuit is shown in Fig. 10.

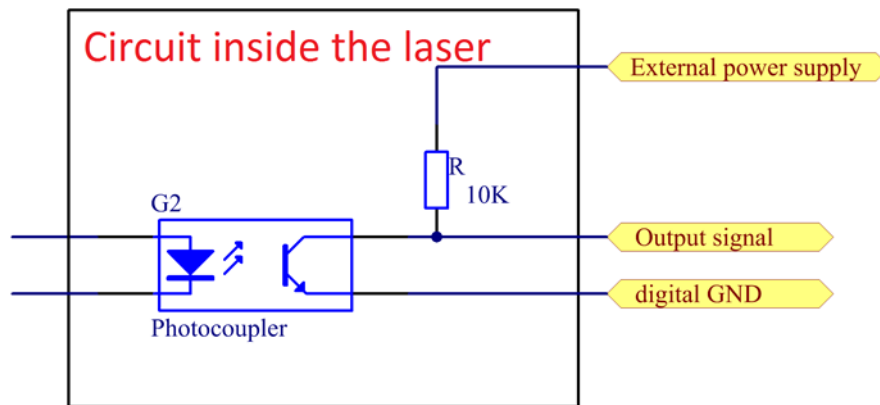

Figure 10: Schematic diagram of output signal interface circuit

4.4.3 RS-232 Serial Port

Figure 11 shows the RS-232 serial port schematic diagram.

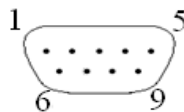

Figure 11 RS-232 serial port schematic diagram.

The pins are defined as follows:

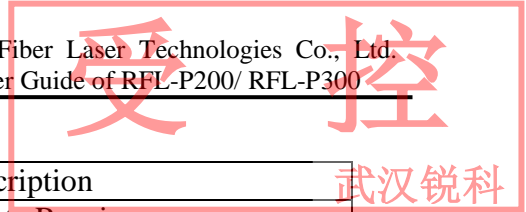

Table 9 RS-232 PIN Description

PIN	Function	Description
2	RXD	Laser Data Receiver
3	TXD	Laser data transmitter
5	GND	Laser data reference
Others	NA	Unconnected in suspension

RS232 interface is a special interface for Raycus internal personnel debugging.

4.5 Application Steps of Laser Device

4.5.1 Pre-inspection

- a) Check whether the size and connection of water pipe are correct, mainly including water temperature, water flow rate, maximum input pressure, refrigeration capacity, whether the water cooler meets the system requirements (see Section 3.3 for details), whether the water cooler valve is opened, etc., to ensure that the water cooler is in normal working state before the laser is opened.
- b) Check whether the appearance of the laser device is normal and whether the output optical cable is bent or falling off.
- c) Check whether there is dust or other dirt in the protective lens of the output optical cable. Use compressed air to confirm whether it can be blown off. If not, wipe it gently with the lens paper dipped in alcohol, and then check it with a special flashlight.
- d) Check whether the power supply and control signal of the laser are connected correctly.
- e) Check whether the emergency stop switch is loose.

4.5.2 Operational Steps

- a) Start-up operation steps

Power on the laser, turn on the air switch, turn on the key switch (the key switch is turned clockwise to ON position, the power indicator lights up,

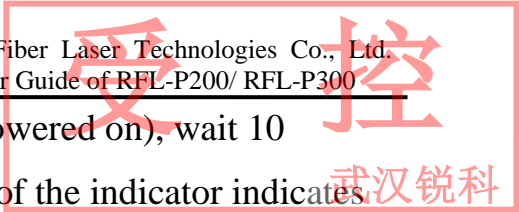

indicating that the main control board has been powered on), wait 10 seconds and then press the laser switch (the light of the indicator indicates that the power module of the laser has been powered on normally).

- b) Operational procedures for checking laser cleaning after laser is turned on
When the device is started normally, the laser power will be increased from 10% to 100% when the laser is first tested. Watch whether the laser is getting stronger and stronger as a cleaning material.

4.5.3 Attention in the process of operation

- a) The repetition frequency range of the laser should not exceed 10-50 kHz.
- b) Do not adjust the laser repetition frequency during marking.
- c) Turn OFF the laser until the power to zero, then turn off the laser power supply, and finally turn off the water cooler.

5 Common Alarms and solutions

The instructions and possible solutions of alarms are as follows:

Table 10 Error instructions and possible solutions

Unit	Potential factors	Preventive measure
1	Low temperature/high temperature alarm of the laser. A high-temperature / low-temperature error occurs when the temperature at the monitoring point exceeds the set upper / lower limit.	Check whether the water-cooling system is normally working, the water temperature is set correctly, and also the water connection is correct. When the water cooling system works normally and the water temperature drops below 30 °C, restart the laser. If the alarm continues, please contact Raycus. Low temperature alarm,. Check whether the actual water temperature of the water is too low. In addition, a low ambient temperature may also cause a low temperature alarm when the laser is cold. Please wait until the water temperature of the water rises above 10 °C and then restate the device. If the alarm continues, please contact Raycus.



2	Please press the LASER button after turning on the key switch for 10 seconds, otherwise the laser will alarm.	The laser alarm can be removed by restarting the laser alarm.
3	The emergency stop button was not released before the laser came out will result the laser alarm	Make sure that the emergency stop button is released before the laser goes out (it can be rotated clockwise, if it is pressed before rotation, it can be released by clockwise rotation of about 1 to 2 circles), then re-energize and the alarm signal is released.
4	When the laser is working, the cleaning head is perpendicular to the surface of the material to be processed, resulting in a large number of feedback light directly into the optical module of the laser, resulting in laser damage. This alarm can only be repaired back to the factory.	Laser cleaning in vertical cleaning is inefficient, and it is easy to cause a large number of feedback light into the laser, resulting in laser burnout.
5	Dust and dirt exist in the protective lens of the laser output optical cable. The light output before cleaning will cause the laser to burn out, which will cause the laser to alarm and restart.	Check the output cable protective lens before laser on.

In addition to the above, if there are any other questions or errors, please contact Raycus to get help.

6 Warranty, Return and Maintenance

6.1 General Warranty

Raycus warrants that all Raycus fiber laser products are conformed to applicable product specifications under normal use and are free from defects in materials and workmanship.

The warranties start on the date of shipment from Raycus for a period of time as set forth in the applicable purchase contracts or product specifications. Raycus has the right to choose to repair or replace any product that proves to be defective in materials and workmanship selectively during the warranty period. Only products with particular defects are under warranty. Raycus reserves the right to issue a credit note for any defective products produced in normal conditions.

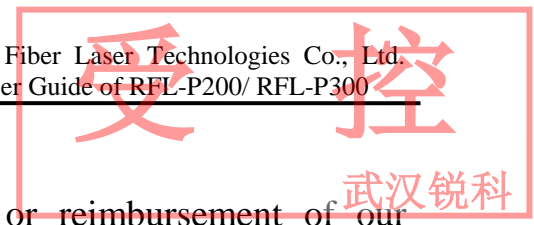

6.2 Limitations of Warranty

The warranty does not cover the maintenance or reimbursement of our product of which the problem results from tampering, disassembling, misuse, accident, modification, unsuitable physical or operating environment, improper maintenance, damages due to excessive use or not following the instructions caused by those who are not from Raycus. The customer has the responsibility to understand and follow this instruction to use the device. Any damage caused by fault operating is not warranted. Accessories and fiber connectors are excluded from this warranty.

According to the warranty, client should write to us within 31 days after the defect is discovered. This warranty does not involve any other party, including specified buyer, end-user or customer and any parts, equipment or other products produced by other companies.

	<p>WARNING: It is the customer's responsibility to understand and follow operating instructions in this User Guide and specifications prior to operation-failure to do so may void this warranty. Accessories and fiber connectors are not covered by this warranty.</p>
---	---

6.3 Service and Repair

- Do not open the device. There are no user serviceable parts, equipment or assemblies for user in this product. All service and maintenance shall be performed by qualified Raycus personnel.
- Please contact Raycus as soon as possible when problems under warranty about maintenance happened to the product.
- The product returned with permission should be placed in a suitable container.
- If any damage happened to the product, please notify the carrier in document immediately.

We reserve the right to make changes in design or constructions of any of our products at anytime without incurring any obligation to make changes or install the same on units previously purchased.

All the items about warranty and service above provided by Raycus are for uses' reference; formal contents about warranty and service are subject to the contract.

© 2021 Wuhan Raycus Fiber Laser technologies Co. Ltd, All Rights Reserved.