

版本号		密级	内部		
A0		阶段 标记		C	
会签	<u>RFL-P20Q</u>				
谢良	<u>20Q 激光器英文说明书</u>				
夏巨江	<u>RFL-P20Q · JS02</u>				
	部 门 <u>脉冲激光器技术研究部</u>				
	编 写 <u>颜鹏晖 20210303</u>				
	校 对 <u>刘 红 20210305</u>				
	审 核 <u>李 科 20210305</u>				
	标 审 <u>李其军 20210305</u>				
	批 准 <u>黄 保 20210308</u>				
旧底图登记号	武汉锐科光纤激光技术股份有限公司				
/					
底图登记号					
/					



# User Instruction

RFL-P20Q

Wuhan Raycus Fiber Laser Technologies CO., Ltd.

2021

# Safety Information

Please read this instruction carefully and familiarize yourself with the information we have provided before you use the product. In this brochure, important operation procedures, safety and other information are provided for you and all future users. In order to ensure operating safely and optimal performance of the product, please do according to following warnings, cautions and other information.

- a) Raycus pulsed fiber laser is classified as a high power Class IV laser device. Before supplying the power to the device, please make sure that the correct voltage of 24V DC power source is connected and the anode and cathode are right. Failure to connect power source correctly will cause damage to the device.
- b) The device emits invisible 1060~1085nm wavelength light with average power 20W. Do not expose your eyes or skin to the radiation of the laser.
- c) Do not take apart the device, because there are no replaceable accessories available for users to use. Any maintenance can only be proceeded in Raycus.
- d) Do not look into the light output end directly. Use appropriate laser safety eyewear when operating the device.

## Safety labels and locations



The two labels above is located on the top of the cover of the device, representing laser radicalization.

# Content

<b>1. Description .....</b>	<b>1</b>
1.1. Product description .....	1
1.2. Actual configuration list .....	1
1.3. Environmental requirements and cautions.....	1
1.4. Specifications • .....	2
<b>2. Mounting.....</b>	<b>3</b>
2.1 Mounting dimensions .....	3
2.2 Method of installation.....	3
<b>3. Control Interface.....</b>	<b>4</b>
<b>4. Operation Regulations.....</b>	<b>7</b>
4.1 Pre-inspection .....	7
4.2 Operation procedures.....	7
4.3 Cautions .....	7
<b>5. Instructions for warranty, return and maintenance .....</b>	<b>8</b>
5.1 General warranty .....	8
5.2 Limitations of warranty .....	8
5.3 Service and repairs.....	8

## 1. Description

### 1.1. Product description

Raycus pulsed laser is an ideal high power laser source with high speed and high efficiency. It is specially designed for industrial laser making system and other applications.

Compared with traditional lasers, pulsed laser has some unique advantages in increasing the conversion efficiency of the pump light 10 times higher. Its low power consumption and automotive design make it appropriate for operating both in and outside the lab. Besides, it is exquisite and convenient for its independence in placement, free time in using and facility in connecting to equipment directly.

The device can emit 1060~1085nm wavelength pulsed light under the control of industrial laser's standard interface driven by 24V DC power source.

### 1.2. Actual configuration list

Table 1. Configuration list

Items	Quantity	Remark
Fiber Laser module	1	
User Guide	2	

### 1.3. Environmental requirements and cautions

Pulsed laser should be driven by 24V DC $\pm$ 1V power source.

- a) Caution: Make sure the corresponding wires of the device are properly grounded.
- b) All the maintenance to the device should only be done by Raycus, because there is no replacement or accessory provided with the device. Please do not try to damage the labels or open the cover in order to prevent against electric shock, or the warranty will be invalid.
- c) The output head of the product is connected with an optical cable. Please be careful handling the output head. Avoid dirt and any other contaminations. Please use the specialized lens paper when cleaning the lens. Please lid the laser with protective cover of the light isolator to be against dirt only when the laser is not installed in the device or not in working.
- d) If the operating the device fails to follow this instruction, the protective function will be weakened. Therefore, it should be used under normal conditions.

- e) Do not install the collimating device into the output head when the laser device is in working.
- f) The device has three cooling fans at the rear panel to dissipate heat. In order to guarantee enough airflow to help giving heat off, there must be a space of at least 10cm's width for airflow in front and rear side of the device. As the cooling fans are working at blow condition, if laser is mounted in a cabinet with fans, the direction should be same as laser's fans.
- g) Do not look into the output head of the device directly. Please do wear appropriate laser safety eyewear during the time when operating the device.
- h) Make sure the pulse repetition rate higher than 20kHz.
- i) For the longest time without pulse is only  $50 \times 10^{-6}$ s. If there is no pulse output, please stopmarking at once, to avoid further damage of the device.
- j) Power source sudden interruption will do great harm to the laser device. Please make sure the power supply works continuously.

#### 1.4. Specifications

Table 2.pulsed fiber laser specifications

Pulsed fiber laser	20
Wavelength (nm)	$1064 \pm 5$
Polarization	Random
Optical isolator	Yes
Nominal average output power (W)	$\geq 20$
Single pulse energy (mJ)	1 @ 20kHz
Beam quality ( $M^2$ )	$< 1.5$
Beam Diameter (mm)	6~8
Pulse duration (ns)	90-110 @ 20kHz
Pulse repetition rate (kHz)	20-60
Output Power Tunability (%)	10-100
Output Fiber Cable length (m)	3
Working voltage (VDC)	$24 \pm 1$
Power consumption (20°C) (W)	170
Cooling	Forced Air Cooled
Dimension W×D×H (mm)	260×391×120
Operating temperature (°C)	0°C ~ 40°C
Store temperature (°C)	-20°C ~ 60°C
humidity (%)	$\leq 80$

## 2. Mounting

### 2.1 Mounting dimensions

- a) Fiber Laser module dimensions (As shown in Fig. 1).

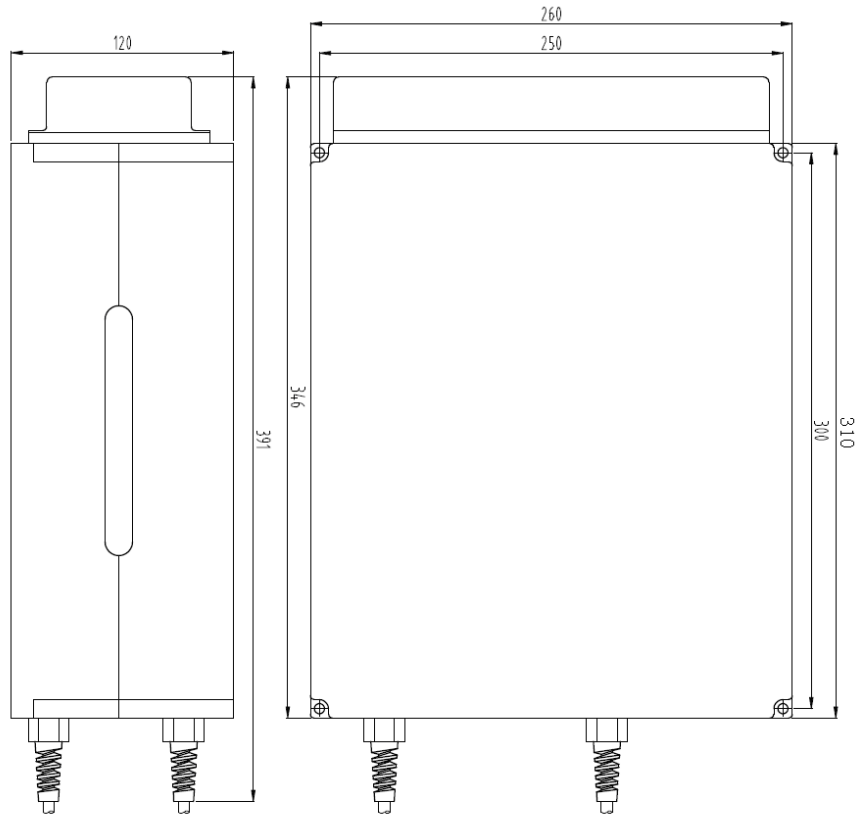

Figure 1. Dimension drawing of laser module(Unit: mm).

- b) Isolated output head dimensions (As shown in Fig. 2).

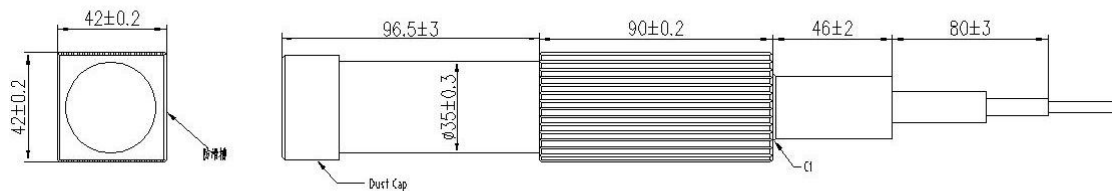

Figure 2. Dimension drawing of output isolator (Unit: mm).

### 2.2 Method of installation

- Fix the module stable to the bracket and keep the laser in good ventilation.
- Connect the power line to 24V DC power and ensure enough DC output power. Keep it clear to the polarity of the electric current: anode-brown; cathode-blue; PE-yellow and

green. The definition figure is shown in Fig. 3.

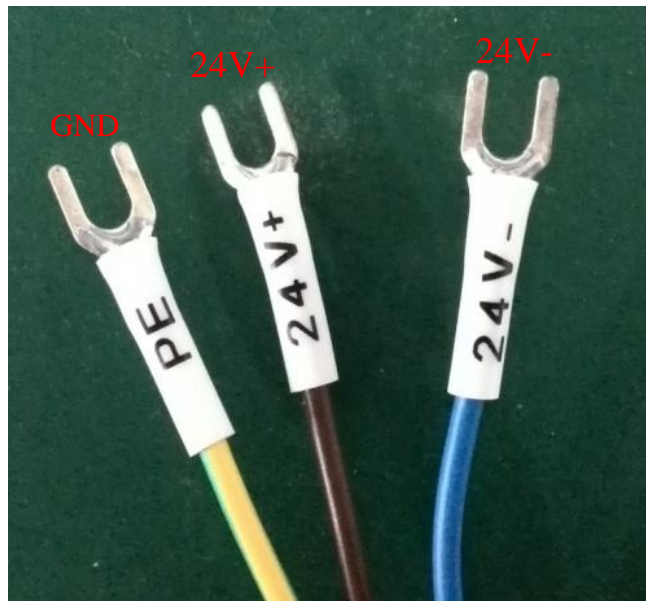

Figure 3. Definition of power line wires

- c) Make sure that the interface of the external controller matches the laser and the control cable is well connected to the laser's interface. The recommended electrical connection is shown in Fig. 4.

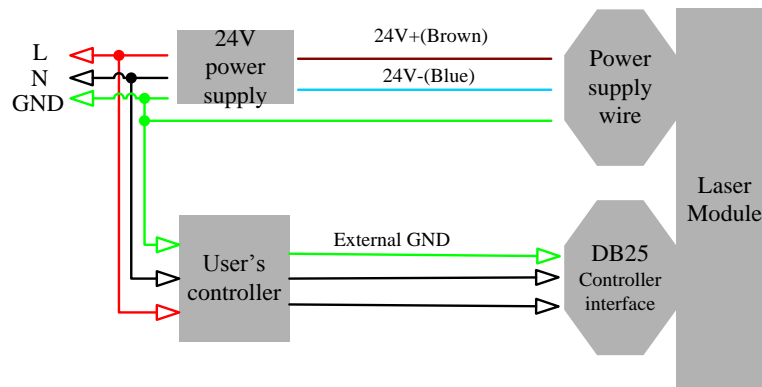

Figure 4. Schematic of recommended electrical connection

- d) The bending radius of the delivery fiber should not exceed 15cm.

### 3. Control Interface

There are DB9 and DB25 interfaces at the rear of the laser. The DB9 is a RS232 interface only used for debugging, no needs to connect. And DB25 is the joint interface connecting control system with laser system, please make sure the connection is reliable before operation. Feet of the DB25 are defined as follows in Fig. 5.



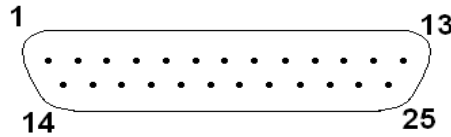

Figure 5. Connect port of controller

Table 3 Definition of connect ports of controller

PIN No.	Name	Description
1-8 (D0-D7)	Power Setting	8 bit Parallel port; D0 is minimum bit and D7 is maximum bit; Range: 0-255 (hexadecimal: 0X00-0XFF); 0 is minimum power and 255 is maximum power.
10,13-15,24-25	Ground	Digital GND
11,12,16,21	Laser alarms status	see alarm codes in the table below
17	VCC	+5V DC power supply input, providing power for inside chips of DB25 to ensure that the input and output signals are valid.
18	EE	Emission Enable (EE) signal. HIGH: Emission Enable LOW or disconnected: Emission Disable
19	EM	Emission Modulation (EM) input. HIGH (>3V): Emission ON LOW or disconnected (<1V): Emission OFF
20	Sync	Pulse Repetition Rate (Synchronization) input, square wave.
22	Guide Laser signal	Guide Laser (red diode) ON/OFF input.
9,23	Obligate PIN	Reserved for Raycus only

- a) The pump current of diode laser and the laser output power are controlled by setting the value of PIN1-PIN8 (TTL level). PIN1-PIN8 can be set from 0 ~ 255, corresponding to the laser output power from 0 ~ 100% (the actual laser power may not be strictly linear with the setting value). The relationship between PIN value and output power is shown in Table 4:
- b) PIN 10,13,14,15,24,25 are all digital GND.
- c) PIN 17 is the external 5V DC input, providing power for inside chips of alarm signal to ensure that alarm signals are valid.
- d) PIN 18 is the start signal of the MO. PIN19 is the input for the optical output signal. The electrical level for both PIN18 and PIN19 are 5V. Before turning on PIN 19, MO signal must be switched ON, in other word, the signal of PIN 18 must be ahead of PIN

19 at least 5 ms, and otherwise the laser machine may be damaged.

Table 4 Definition of power control PIN value

	Setting 1	Setting 2	Setting 3	Setting 4	Setting 5
PIN 1	0	0	0	0	1
PIN 2	0	0	0	0	1
PIN 3	0	0	0	0	1
PIN 4	0	0	0	0	1
PIN 5	0	0	0	1	1
PIN 6	0	0	1	1	1
PIN 7	0	1	1	1	1
PIN 8	1	1	1	1	1
Current	~50 %	~75 %	~87.5 %	~93.75 %	100%

- e) PIN 20 provides control of the frequency. The frequency range should be 20kHz~60 kHz, depends on the varying power levels of different laser machines.

**ATTENTION: The frequency signal must be ahead of the EM signal at least 5 ms, otherwise the laser machine may be damaged.**

- f) Definition of alarm signal

Table 5 Definition of warning signal

PIN 12	PIN 11	PIN 16	PIN 21	Alarm item
×	Low	Low	Low	Temperature alarm
×	Low	Low	High	Normal
×	Low	High	High	System alarm
×	High	Low	Low	Supply voltage

- g) Internal circuit of input/output signal

Internal circuit of input signal: (current of input signal must be greater than 7mA)

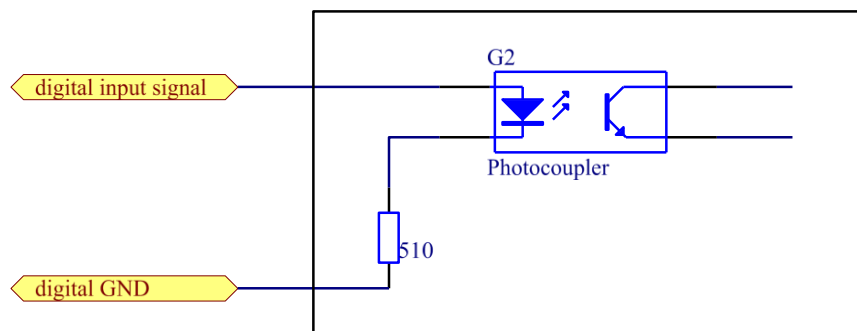

Figure 6. Internal circuit of input signal

Internal circuit of output signal:

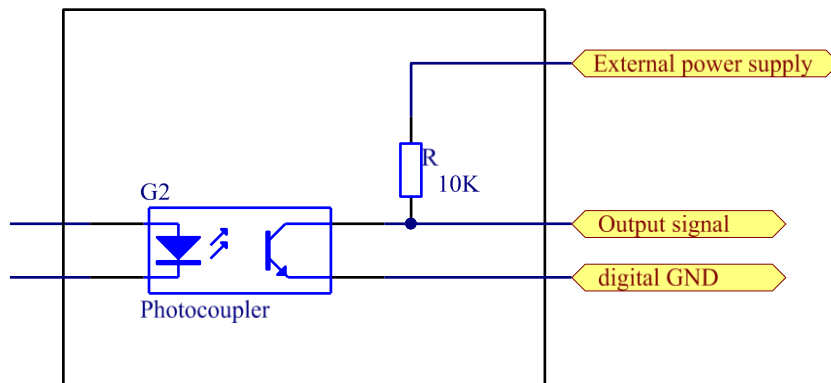

Figure 7. Internal circuit of output signal

## 4. Operation Regulations

### 4.1 Pre-inspection

- a) Make sure the device appearance is in good condition and the output fiber is neither excessively bended nor broken.
- b) Make sure signal line of laser and marking system are properly connected.

### 4.2 Operation procedures

#### a) Starting procedures

Please make sure the control system is on before you turn on the fiber laser. Only after at least 1 minute since the power turned on, the subsequent operations can be preceded.

#### b) Frequency set introductions

For model IP20Q, the frequency setting range is from 20kHz to 60kHz.

#### c) Laser marking checking

- d) For the device initial testing, first turn the power down to zero without turning on the marking system after the device is successfully started. Then draw a quadrature, marking continuously while slowly increasing the power from zero to 100% at the same time. Meanwhile, use a ceramic material to observe the laser and the laser should become stronger, otherwise shut down the device and check. If operating normally, the marking system can be used in common order afterwards.

### 4.3 Cautions

- a) Marking frequency must be in the range of 20~60 kHz.

- b) It should not modulate the frequency while marking.
- c) Stop marking first before shutting down the device, then turn the power down to zero and cut the power off.

## **5. Instructions for warranty, return and maintenance**

### **5.1 General warranty**

All products are warranted by Raycus against defects and problems in materials and workmanship during the warranty period according to the purchase order or specifications and we guarantee the product will accord with the specification under normal use.

Raycus has the right to choose to repair or replace any product that proves to be defective in materials and workmanship selectively during the warranty period. Only products with particular defects are under warranty. Raycus reserves the right to issue a credit note for any defective products produced in normal conditions.

### **5.2 Limitations of warranty**

The warranty does not cover the maintenance or reimbursement of our product of which the problem results from tampering, disassembling, misuse, accident, modification, unsuitable physical or operating environment, improper maintenance, damages due to excessive use or not following the instructions caused by those who are not from Raycus. Customer has the responsibility to understand and follow this instruction to use the device. Any damage caused by fault operating is not warranted. Accessories and fiber connectors are excluded in this warranty.

According to the warranty, client should write to us within 31days since the defect is discovered. This warranty does not involve any other party, including specified buyer, end-user or customer and any parts, equipment or other products produced by other companies.

### **5.3 Service and repairs**

Raycus is responsible for all the maintenance, for there is no accessory available inside for users to use. Please contact Raycus as soon as possible when problems under warranty about maintenance happen to the product. The product returned with permission should be placed in a suitable container. If any damage happens to the product, please notify the carrier in document immediately.

**All the items about warranty and service above provided by Raycus are only for reference; formal contents about warranty and service are subject to the contract.**

---

© 2021Wuhan Raycus Fiber Laser Technologies Co. Ltd.  
All Rights Reserved.